

Snapshot

The **FX-22P+** is a three housing water treatment system with 20" drop-in cartridges that reduces sediment down to 0.5 micron and reduces chlorine, taste & odor at a flow rate of 6.0 gpm for 60,000 gallons. The system includes a five micron prefilter for added protection on water supplies and excessive dirt and sediment.

System Benefits

- Improves the quality and consistency of cold and hot beverages.
- Reduces maintenance frequency and cost, and extends equipment life.
- 5 micron Polytrix prefilter provides added protection against excessive sediment found in some water supplies.
- Gradient-density depth filtration reduces dirt, rust, and other debris as small as 1/2 micron to assure clean, clear water and protect solenoids, valves and other fittings against wear and plugging.
- High capacity activated carbon filtration makes water taste great and protects equipment against corrosive chlorine.
- Reduced sediment, chlorine and taste & odor can improve beverage ingredient efficiency.
- White powder coated heavy gauge steel mounting bracket and full-flow inlet shut-off valve makes installation simple.
- Built-in pressure gauge allows visual monitoring of operating pressure.
- Inlet shut-off and depressurization valves make changing the filter quick and simple.
- Generates less waste, only the drop-in cartridge is replaced. No discarding of metal or plastic quick-change filters.
- Replacement cartridge cost per gallon is much less than proprietary quick-change filters.
- NSF Certified under Standard 42.

ITEM #: _____ QTY: _____

JOB NAME/NUMBER _____



Application

FOUNTAIN BEVERAGES - Up to 150 bag-in-box per month / multiple carbonators up to 6 gpm flow rate. Includes prefilter for water supplies with high turbidity levels.

COMBINATION APPLICATIONS - Service multiple points-of-use.

Installation Tips

- Feed-water connection to system should be COLD only.
- Do not exceed system specifications for temperature and pressure.
- Allow 3" clearance below system for filter housing removal and cartridge replacement.
- Detailed installation, operation & maintenance manual is included with each system.
- No activation procedure or flushing is required for system to perform as specified.

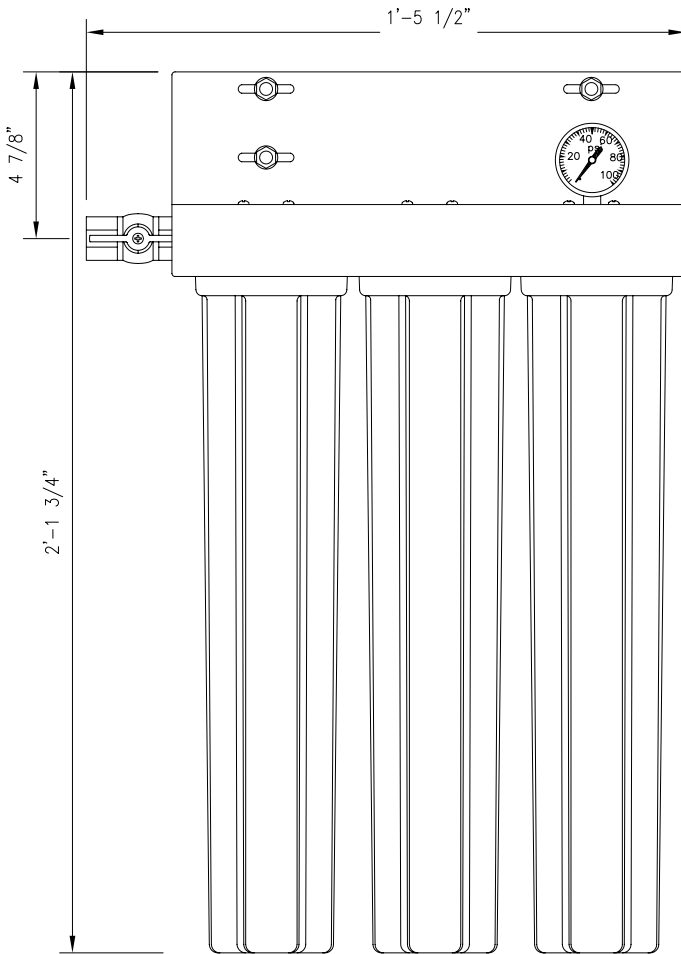

Model FX-22P+ is tested and certified by NSF International against NSF/ANSI Standard 42 for the reduction of:
Standard 42: Aesthetic Effects,
Chlorine Reduction
Taste and Odor Reduction
Nominal Particulate Reduction, Class 1

Dealer/Distributor Info:

► Specifications

System	
Dimensions (Height x Width X Depth, inches)	25 3/4" x 17 1/2" x 9 3/4"
Connection - Inlet & Outlet	1/2" NPT female
Operating Pressure Range	10-125 psi (0.7 -8.6 bar)
Inlet Water Temperature Range	35° -100° F (2° -38° C)
Shipping Weight	32 lbs.
Performance	
Chlorine, Taste and Odor Reduction Capacity	60,000 gals (226,800 liters)
Service Flow Rate	6.0 gpm (22.7 lpm)
Sediment Reduction	.5 micron (nominal)

Optional Flush Valve Kit - Part #: 160-52910

► Replacement Cartridge(s)

Model	Part Number	Qty
S5-20	252-10120	1
CTO-20	252-20120	2

It is recommended that filters be changed every six months, when capacity is reached or when effluent pressure or flow becomes inadequate.

This product is for commercial use only and must be installed and maintained according to manufacturers guidelines.

Do not use on water that is microbiologically unsafe or of unknown quality without adequate disinfection before or after the system.

► Warranty

Systems have a 3 year warranty against defects in material and workmanship. For complete warranty information contact OptiPure customer service or go to www.optipurewater.com.

OptiPure, Mfg. by Procam Controls, Inc.
2605 Technology Dr., Bldg 300
Plano, TX 75074
p: 972.881.9797; f: 972.422.6262
www.optipurewater.com