

ITEM #: _____ QTY: _____

JOB NAME/NUMBER _____

Snapshot

The OptiPure® OP70/5 utilizes reverse osmosis (RO) to remove >97% of the total dissolved solids (TDS) from water. Then a balance of minerals is dissolved into the RO water to provide “optimized” water with desirable TDS for the recommended applications. The system operates at line pressure and can produce up to 70 gallons per day of optimal quality water. The compact OP70 processor can be wall-mount or installed under counter and includes integrated pre-filtration with particulate and chlorine reduction. System includes a built-in full system bypass valve. System also includes a 5 gallon hydropneumatic storage tank and hose, tubing and fittings required for installation.



System Benefits

- Virtually eliminates scale & corrosion problems related to high TDS, water hardness or chlorides.
- High capacity pre-filtration protects the membrane against damaging chlorine and reduces filter replacement frequency.
- Sealed hydropneumatic storage tank provides pressure to downstream equipment.
- Integrated system bypass valve eliminates down-time or service interruptions.
- System prefilter includes auxiliary connection port for filtered water applications.
- Compact, modular design enables installation under counters and in tight spaces.
- Non-electric design operates on available water pressure.
- Simple, easy-to-service and maintain design.

Application

Steam Equipment
Proofers & Humidifiers
Misting Systems

Installation Tips

- Feed-water connection to system should be COLD only.
- Do not exceed system specifications for temperature and pressure.
- Provide a dedicated water line of at least 3/8" I.D. to the unit for consistent flow and pressure to the system.
- Allow 3" clearance below system for filter cartridge removal and replacement.
- Detailed installation, operation & maintenance manual is included with each system.

Specifications

System		
Dimensions	Processor Tank	14.5"Hx12.4"Wx7"D 20.3"Hx12.3"dia.
Connection - Feedwater		3/8" Push Fit Tubing
Operating Pressure Range		60-85 psi at 0.5 gpm (3.5 -5.9 bar)
Inlet Water Temperature Range		40° -100° F (4° -38° C)
Shipping Weight		25 lbs.
Drain Connection		2 GPM Minimum Flow
Performance		
Typical TDS* Rejection		97+%
Product Water Production (at 77°F, 60psi Net Operating Pressure)		70 gals/day 2.9 gals/hr
<i>Production rate is strictly dependent on feed water temperature and pressure.</i>		
Storage Tank Capacity		5 gals.

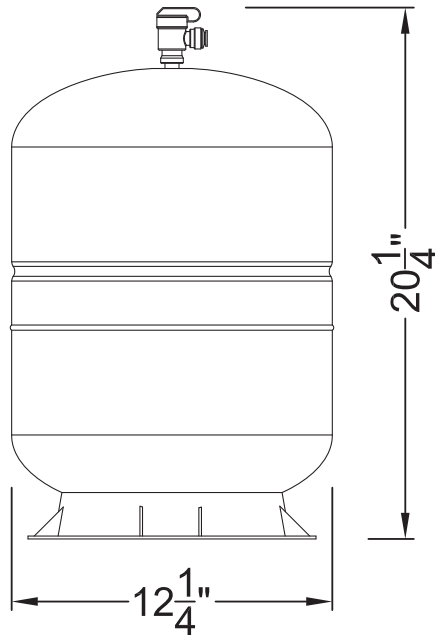
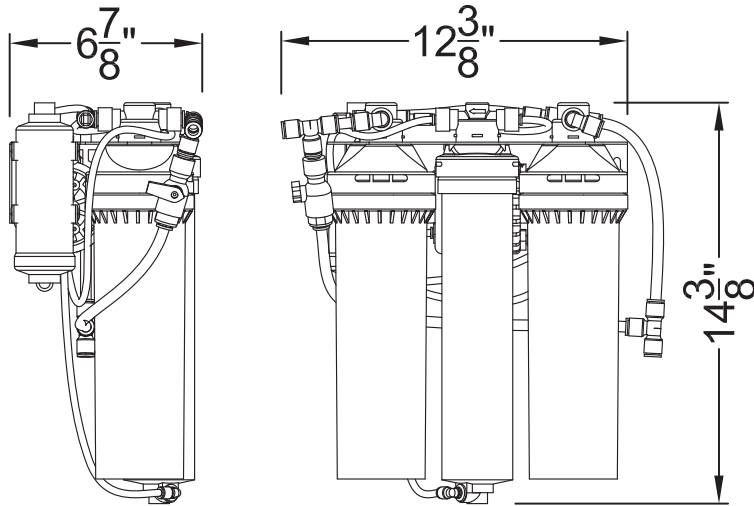

Feed-Water Chemistry

Feed TDS	Up to 1200 ppm
Feed pH	6-10
Hardness*	12 grains or less
Free Chlorine	<2 mg/l
Iron	0.1 mg/l max
Turbidity	0.05 NTU
Manganese	0.05 mg/l max
Hydrogen Sulfide	0.0 mg/l

*For water outside of these parameters call OptiPure technical service.

Dealer/Distributor Info:

Replacement Media

Description	Part Number	Qty
Pre/Post-filter	300-05828	2
AMS Membrane	204-52810	1
Mineral Addition	252-70260	1

It is recommended that pre/post-filters & mineral addition cartridge be changed every 6 months, when capacity is reached or when feedwater pressure or flow becomes inadequate.

Membrane life varies depending on feedwater conditions and pre-filter maintenance. It is 12-18 months under typical conditions, but it can be as long as 3-5 years.

This product is for commercial use only and must be installed and maintained according to manufacturer's guidelines.

Do not use on water that is microbiologically unsafe or of unknown quality without adequate disinfection before or after the system.

Warranty

Systems have a 1 year warranty against defects in material and workmanship. Warranty does not include filters or membranes. For complete warranty information contact OptiPure customer service or go to the OptiPure website.