

OptiPure

Snapshot

The **FXWS-12B** is a single-housing water treatment system with a drop-in 4.5" x 20" high-capacity ion-exchange (softening) cartridge that removes calcium and magnesium hardness minerals from water. The system also takes out dirt and sediment down to 10-microns. The system can be used as a point-of-use softening filter, or it can be applied to a specific point-of-use down-line in combination with a primary system.

System Benefits

- Takes out hardness minerals that form damaging scale (lime-scale).
- Reduces maintenance frequency and cost, and extends equipment life.
- Reduces dirt, rust and other debris as small as 10-microns.
- Sturdy, powder-coated mounting bracket and full-flow inlet shut-off valve simplify installation.
- Built-in pressure gauge allows visual monitoring of when filters need to be changed.
- Inlet shut-off and depressurization valves make filter replacement quick and simple.
- Minimizes waste by only replacing drop-in cartridge and reusing filter sump.

Model: **FXWS-12B**

Part #: 160-00520

ITEM #: _____ QTY: _____

JOB NAME/NUMBER _____



Application

ESPRESSO - traditional, semi-auto and super-automatic machines.

TEA BREWERS

Installation Tips

- Feed-water connection to system should be COLD only.
- Do not exceed system specifications for temperature and pressure.
- Allow 3" clearance below system for filter housing removal and cartridge replacement.
- Do not use for condenser water.
- Detailed installation, operation and maintenance manual included with each system.
- Flush the cartridge for two minutes prior to connecting equipment.



Model: **FXWS-12B**
Part #: 160-00520

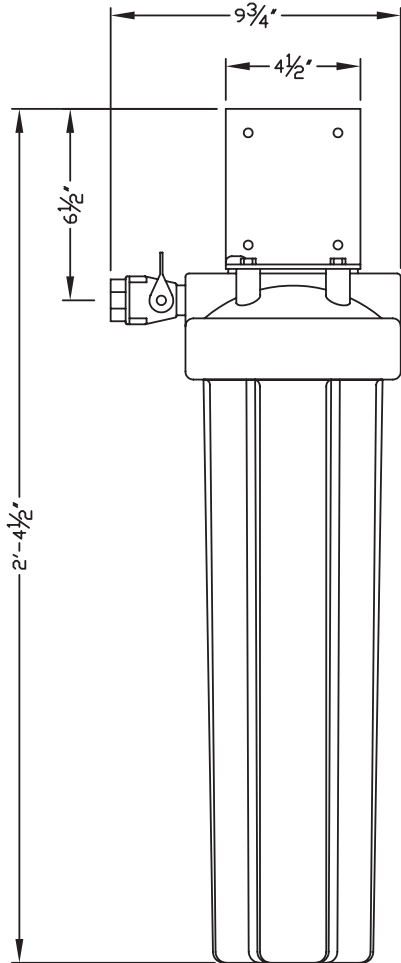

WARNING:
Cancer and Reproductive Harm -
www.P65Warnings.ca.gov.

► Specifications

System	
Dimensions (Height x Width x Depth, Inches)	28.5" h x 9.8" w x 8.5" d
Connection - Inlet & Outlet	3/4" FNPT
Operating Pressure Range	10 - 125 psi (0.7 - 8.6 bar)
Inlet Water Temperature Range	35° - 100° F (2° - 38° C)
Shipping Weight	22 lbs.
Performance	
Water Softening Capacity	5,200 grains
Service Flow Rate	2.0 gpm (7.6 lpm)
Sediment Reduction	10 microns (nominal)
Scale Prevention	Ion Exchange

► Replacement Cartridge(s)

Model	Part Number	Qty
WS-20B	252-60040	1

► Options

Model	Description	Part Number
Flush Valve Kit	FX Flush Valve Kit	160-52914

It is recommended that pre/post-filters and mineral addition cartridges are changed every 6 months, when capacity is reached or when feedwater pressure or flow becomes inadequate.

Membrane life varies depending on feedwater conditions and pre-filter maintenance. It is 12-18 months under typical conditions, but it can be as long as 3-5 years.

This product is for commercial use only and must be installed and maintained according to manufacturer's guidelines.

Do not use on water that is microbiologically unsafe or of unknown quality without adequate disinfection before or after the system.

► Warranty

All system components and assembly except for filter cartridges, separation membranes, permeate pumps, electric motors, diaphragm pumps, and rotary vane pumps shall be warranted against defects in workmanship for a period of 60 months from the date of original shipment. For complete warranty information, contact OptiPure customer service or go to www.optipurewater.com.

Dealer/Distributor Info:

OptiPure, A Division of Aquion, Inc.

101 S. Gary Ave., Suite A
Roselle, IL 60172

p: 972.881.9797 e: info@optipure.net
www.optipurewater.com