

# OptiPure

## Snapshot

The FXTS-11 is a single-housing water treatment system with a drop-in 10" cartridge that protects equipment against damaging scale (lime scale) and takes out dirt and sediment down to 5-microns. The system includes IsoNet®, OptiPure's patented scale-inhibiting technology, which delivers consistent protection against the precipitation and accumulation of scale and provides a protective barrier to help guard against corrosion.

## System Benefits

- Protects equipment against scale and corrosion.
- Reduces maintenance frequency and cost, and extends equipment life.
- Gradient-density sediment filtration protects against dirt, rust and other debris down to 5-microns.
- Sturdy mounting bracket and full-flow inlet shut-off valve simplify installation.
- Minimizes waste by only replacing drop-in cartridge and reusing filter sump.
- Chlorine remains in the water to help protect an ice machine against microbial contamination when used as a point-of-use filter.

Model: **FXTS-11**  
Part #: 160-50003

ITEM #: \_\_\_\_\_ QTY: \_\_\_\_\_  
JOB NAME/NUMBER \_\_\_\_\_



## Application

ICE - Cubers up to 1,000 lbs. and Flakers up to 1,500 lbs.

## Installation Tips

- Feed-water connection to system should be COLD only.
- Do not exceed system specifications for temperature and pressure.
- Allow 3" clearance below system for filter housing removal and cartridge replacement.
- Connect filtered water line to ice-production connections only. Do not use for condenser water.
- Detailed installation, operation and maintenance manual included with each system.
- No activation procedure or flushing required for system to perform as specified.



Model: **FXTS-11**  
Part #: 160-50003

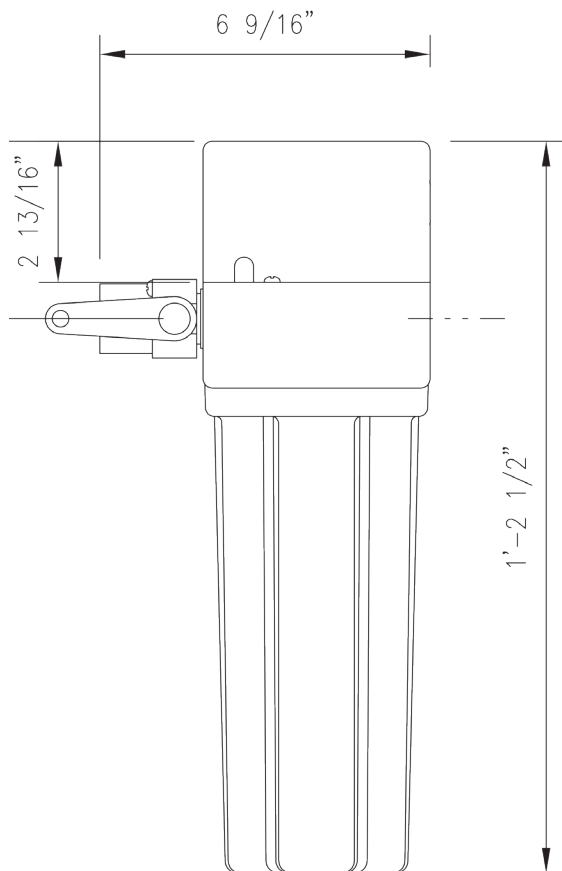

## ► Specifications

System	
Dimensions (Height x Width x Depth, Inches)	14.5" h x 6.5" w x 5.1" d
Connection - Inlet & Outlet	1/2" FNPT
Operating Pressure Range	10 - 125 psi (0.7 - 8.6 bar)
Inlet Water Temperature Range	35° - 100° F (2° - 38° C)
Shipping Weight	6 lbs.
Performance	
Service Flow Rate	2.5 gpm (7.6 lpm)
Sediment Reduction	5 microns (nominal)
Scale & Corrosion Inhibitor	IsoNet (70 grams)

## ► Replacement Cartridge(s)

Model	Part Number	Qty
PTS-10	252-00810	1

## ► Options

Model	Description	Part Number
Flush Valve Kit	FX Flush Valve Kit	160-52910



## ► Warranty

All system components and assembly except for filter cartridges, separation membranes, permeate pumps, electric motors, diaphragm pumps, and rotary vane pumps shall be warranted against defects in workmanship for a period of 60 months from the date of original shipment. For complete warranty information, contact OptiPure customer service or go to [www.optipurewater.com](http://www.optipurewater.com).

It is recommended that pre/post-filters and mineral addition cartridges are changed every 6 months, when capacity is reached or when feedwater pressure or flow becomes inadequate.

Membrane life varies depending on feedwater conditions and pre-filter maintenance. It is 12-18 months under typical conditions, but it can be as long as 3-5 years.

This product is for commercial use only and must be installed and maintained according to manufacturer's guidelines.

Do not use on water that is microbiologically unsafe or of unknown quality without adequate disinfection before or after the system.

Dealer/Distributor Info:

**OptiPure, A Division of Aquion, Inc.**  
101 S. Gary Ave., Suite A  
Roselle, IL 60172  
p: 972.881.9797 e: [info@optipure.net](mailto:info@optipure.net)  
[www.optipurewater.com](http://www.optipurewater.com)