

OptiPure

Model: **FX11+CR**

Part #: 160-50012

Snapshot

The FX11+CR is a dual-housing water treatment system with drop-in cartridges that reduces sediment down to 0.5-microns and reduces chlorine up to 20,000-gallons at 3.0 gpm and chloramine at a flow rate of 0.5 gpm for 10,000-gallons.

System Benefits

- Reduces maintenance frequency and cost, and extends equipment life.
- Gradient-density sediment filtration protects against dirt, rust and other debris down to 0.5-microns.
- Catalytic-carbon filtration provides added protection against chloramines that may be present in water supplies.
- High-capacity activated-carbon filtration makes water taste great and protects equipment against corrosive chlorine.
- Improves equipment operating efficiency.
- Sturdy mounting bracket and full-flow inlet shut-off valve simplify installation.
- Built-in pressure gauge allows visual monitoring of when filters need to be changed.
- Inlet shut-off and depressurization valves make filter replacement quick and simple.
- Minimizes waste by only replacing drop-in cartridges and reusing filter sumps.

ITEM #: _____ QTY: _____

JOB NAME/NUMBER: _____



Application

STEAM & COMBI OVENS - For the reduction of chloramines, chlorine and sediment.

COFFEE & TEA - Applications where water hardness is not a problem.

Installation Tips

- Feed-water connection to system should be COLD only.
- Do not exceed system specifications for temperature and pressure.
- Allow 3" clearance below system for filter housing removal and cartridge replacement.
- Connect filtered water line to ice and steam production connections only. Do not use for condenser water.
- Detailed installation, operation and maintenance manual included with each system.
- No activation procedure or flushing required for system to perform as specified.



Model: **FX11+CR**
Part #: 160-50012

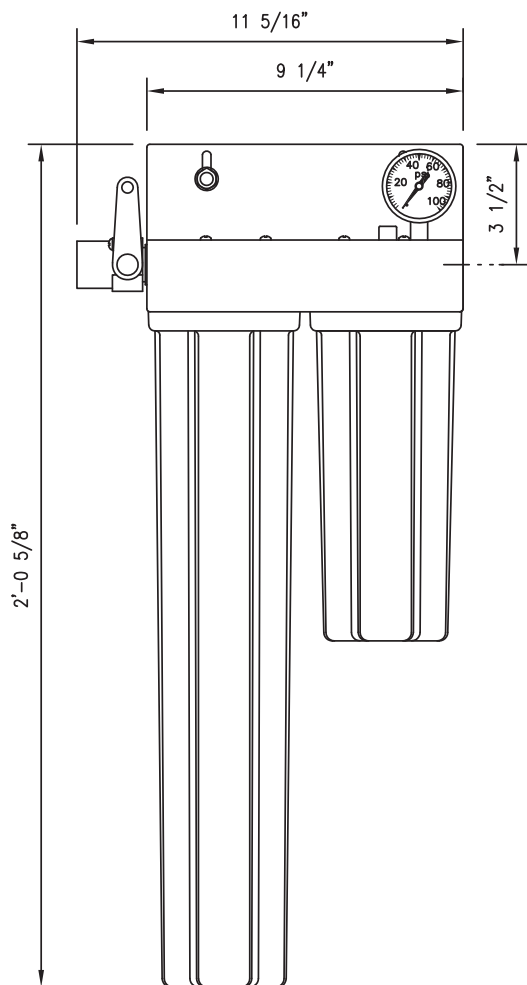

WARNING:
Cancer and Reproductive Harm -
www.P65Warnings.ca.gov.

► Specifications

System	
Dimensions (Height x Width x Depth, inches)	24.6"h x 11.3"w x 5.8"d
Connection - Inlet & Outlet	1/2" NFPT
Operating Pressure Range	10 - 125 psi (0.7 - 8.6 bar)
Inlet Water Temperature Range	35° - 100° F (2° - 38° C)
Shipping Weight	14 lbs.
Performance	
Chlorine Reduction Capacity at 3.0 gpm (11.4 lpm)	20,000 gals. (75,708 L)
Chloramine Reduction Capacity at 0.5 gpm (1.9 lpm)	10,000 gals. (37,800 L)
Service Flow Rate (Chlorine Reduction)	3.0 gpm (11.4 lpm)
Sediment Reduction	0.5 micron (nominal)

► Replacement Cartridge(s)

Model	Description	Part Number	Qty
CCM-20	Filter	252-20620	1
CTO-10	Filter	252-20110	1

► Options

Model	Description	Part Number
Flush Valve Kit	FX Flush Valve Kit	160-52910

It is recommended that pre/post-filters and mineral addition cartridges are changed every 6 months, when capacity is reached or when feedwater pressure or flow becomes inadequate.

Membrane life varies depending on feedwater conditions and pre-filter maintenance. It is 12-18 months under typical conditions, but it can be as long as 3-5 years.

This product is for commercial use only and must be installed and maintained according to manufacturer's guidelines.

Do not use on water that is microbiologically unsafe or of unknown quality without adequate disinfection before or after the system.

► Warranty

All system components and assembly except for filter cartridges, separation membranes, permeate pumps, electric motors, diaphragm pumps, and rotary vane pumps shall be warranted against defects in workmanship for a period of 60 months from the date of original shipment. For complete warranty information, contact OptiPure customer service or go to www.optipurewater.com.

Dealer/Distributor Info:

OptiPure, A Division of Aquion, Inc.
101 S. Gary Ave., Suite A
Roselle, IL 60172
p: 972.881.9797 e: info@optipure.net
www.optipurewater.com