

OptiPure

Snapshot

The **FX-22B** is a dual-housing water treatment system with drop-in 4.5" x 20" cartridges that reduces sediment down to 5-microns and reduces chlorine, taste & odor at a flow rate of 5.0 gpm for 100,000-gallons.

System Benefits

- Improves quality and consistency of cold and hot beverages.
- Reduces maintenance frequency and cost, and extends equipment life.
- Gradient-density sediment filtration protects against dirt, rust and other debris down to 5-microns.
- High-capacity activated-carbon filtration makes water taste great and protects equipment against corrosive chlorine.
- Sturdy mounting bracket and full-flow inlet shut-off valve simplify installation.
- Built-in pressure gauge allows visual monitoring of when filters need to be changed.
- Inlet shut-off and depressurization valves make filter replacement quick and simple.
- Minimizes waste by only replacing drop-in cartridge and reusing filter sump.

Model: **FX-22B**

Part #: 160-50042

ITEM #: _____ QTY: _____

JOB NAME/NUMBER _____



Application

FOUNTAIN BEVERAGES - 2 to 3 carbonators.

COFFEE & TEA - High-volume applications where water hardness is not a problem.

DRINKING WATER

Installation Tips

- Feed-water connection to system should be COLD only.
- Do not exceed system specifications for temperature and pressure.
- Allow 3" clearance below system for filter housing removal and cartridge replacement.
- Detailed installation, operation and maintenance manual included with each system.
- No activation procedure or flushing required for system to perform as specified.



Model: **FX-22B**
Part #: 160-50042

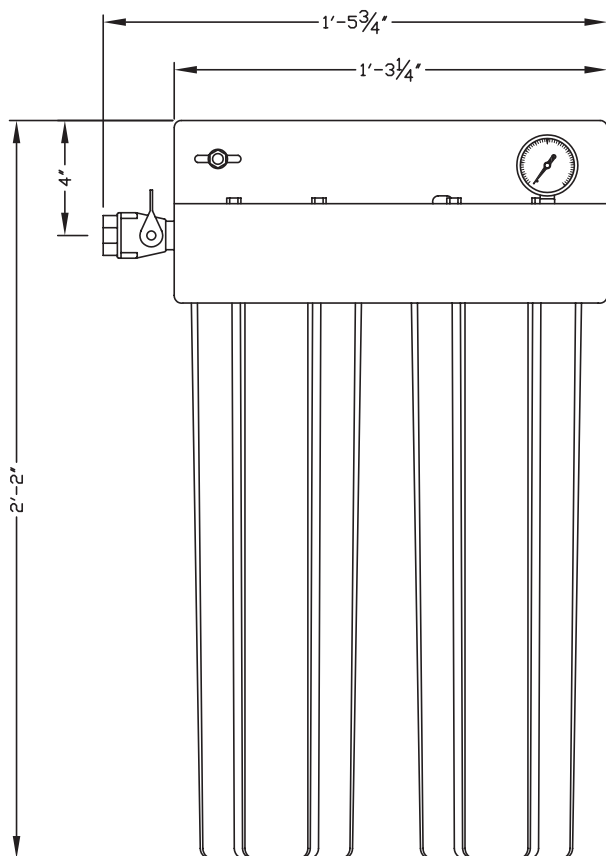

Model FX-22B is independently tested for:
Chlorine Reduction
Taste and Odor Reduction
Nominal Particulate Reduction

WARNING:
Cancer and Reproductive Harm -
www.P65Warnings.ca.gov

► Warranty

All system components and assembly except for filter cartridges, separation membranes, permeate pumps, electric motors, diaphragm pumps, and rotary vane pumps shall be warranted against defects in workmanship for a period of 60 months from the date of original shipment. For complete warranty information, contact OptiPure customer service or go to www.optipurewater.com.

Dealer/Distributor Info:

► Specifications

System	
Dimensions (Height x Width x Depth, Inches)	26"h x 17.8"w x 8.5"d
Connection - Inlet & Outlet	3/4" FNPT
Operating Pressure Range	10 - 125 psi (0.7 - 8.6 bar)
Inlet Water Temperature Range	35° - 100° F (2° - 3° °C)
Shipping Weight	18 lbs.
Performance	
Chlorine, Taste and Odor Reduction Capacity	100,000 gals. (378,541 L)
Service Flow Rate	5.0 gpm (18.9 lpm)
Sediment Reduction	5 microns (nominal)
Scale & Corrosion Inhibitor	N/A

► Replacement Cartridge(s)

Model	Part Number	Qty
CTO-20B	252-20420	2

► Options

Model	Description	Part Number
Flush Valve Kit	FX Flush Valve Kit	160-52914

It is recommended that pre/post-filters and mineral addition cartridges are changed every 6 months, when capacity is reached or when feedwater pressure or flow becomes inadequate.

Membrane life varies depending on feedwater conditions and pre-filter maintenance. It is 12-18 months under typical conditions, but it can be as long as 3-5 years.

This product is for commercial use only and must be installed and maintained according to manufacturer's guidelines.

Do not use on water that is microbiologically unsafe or of unknown quality without adequate disinfection before or after the system.

OptiPure, A Division of Aquion, Inc.

101 S. Gary Ave., Suite A
Roselle, IL 60172

p: 972.881.9797 e: info@optipure.net
www.optipurewater.com