



Model: **QTC-1**
Part #: 160-52014

ITEM #: _____ QTY: _____

JOB NAME/NUMBER _____

Snapshot

The **QTC-1** is a single-cartridge water treatment system with a 15" Qwik-Twist cartridge that reduces sediment down to 0.5-microns and reduces chlorine, taste & odor at a flow rate of 2.25 gpm for 22,500-gallons. The system also reduces turbidity and health-related contaminants such as cysts.

System Benefits

- NSF certified under standard 53 to reduce harmful cysts such as cryptosporidium and giardia. Also Certified under NSF Standard 42.
- Improves quality and consistency of cold and hot beverages.
- Reduces maintenance frequency and cost, and extends equipment life.
- Gradient-density sediment filtration protects against dirt, rust and other debris down to 0.5-microns.
- High-capacity activated-carbon filtration makes water taste great and protects equipment against corrosive chlorine.
- Sturdy mounting bracket and full-flow inlet shut-off valve simplify installation.
- Built-in pressure gauge allows visual monitoring of when filters need to be changed.
- Inlet shut-off valve makes filter replacement quick and simple.
- Utilizes Qwik-Twist cartridges that make changing filters quick, easy and sanitary.



Application

FOUNTAIN BEVERAGES - Single carbonator.

COFFEE & TEA - Applications where water hardness is not a problem.

DRINKING WATER

Installation Tips

- Feed-water connection to system should be **COLD** only.
- Do not exceed system specifications for temperature and pressure.
- Allow 3" clearance below system for filter cartridge removal and replacement.
- Detailed installation, operation and maintenance manual included with each system.
- No activation procedure or flushing required for system to perform as specified.

OptiPure

Model: **QTC-1**
Part #: 160-52014

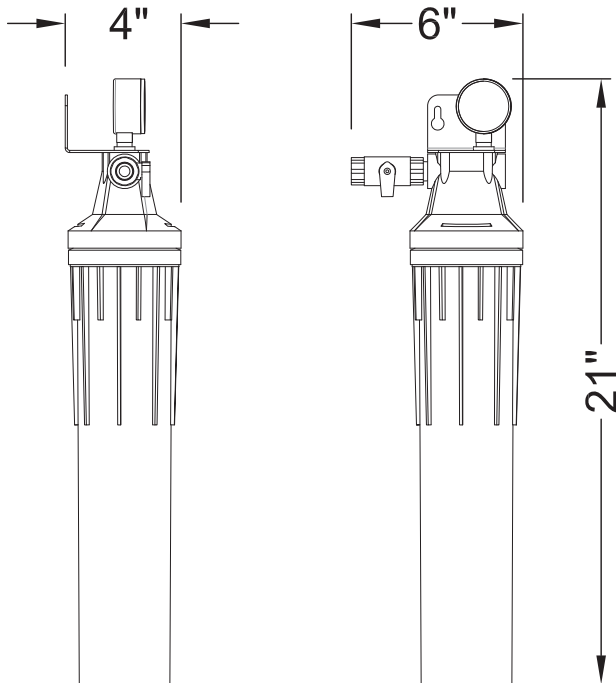

System Tested and Certified by NSF International against NSF/ANSI Standard 42 and 53: Aesthetic Effects - Particulate Reduction (Class I) and the reduction of Chlorine, Taste and Odor, and Cyst Reduction

WARNING:
Cancer and Reproductive Harm -
www.P65Warnings.ca.gov

► Warranty

All system components and assembly except for filter cartridges, separation membranes, permeate pumps, electric motors, diaphragm pumps, and rotary vane pumps shall be warranted against defects in workmanship for a period of 60 months from the date of original shipment. For complete warranty information, contact OptiPure customer service or go to www.optipurewater.com.

Dealer/Distributor Info:

► Specifications

System	
Dimensions (Height x Width x Depth, Inches)	21"h x 6"w x 4"d
Connection - Inlet & Outlet	3/8" FNPT
Operating Pressure Range	10 - 125 psi (0.7 - 8.6 bar)
Inlet Water Temperature Range	35° - 100° F (2° - 38° C)
Shipping Weight	5 lbs.
Performance	
Chlorine, Taste and Odor Reduction Capacity	22,500 gals. (85,162 L)
Service Flow Rate	2.25 gpm (8.50 lpm)
Sediment Reduction	0.5 microns (nominal)
Reduces Harmful Cysts	Yes
Reduces Turbidity	Yes
Scale & Corrosion Inhibitor	N/A

► Replacement Cartridge(s)

Model	Part Number	Qty
XTO-Q	300-05840	1

► Options

Model	Description	Part Number
Flush Valve Kit	QT Flush Valve Kit	160-52912

It is recommended that pre/post-filters and mineral addition cartridges are changed every 6 months, when capacity is reached or when feedwater pressure or flow becomes inadequate.

Membrane life varies depending on feedwater conditions and pre-filter maintenance. It is 12-18 months under typical conditions, but it can be as long as 3-5 years.

This product is for commercial use only and must be installed and maintained according to manufacturer's guidelines.

Do not use on water that is microbiologically unsafe or of unknown quality without adequate disinfection before or after the system.

OptiPure, A Division of Aquion, Inc.

101 S. Gary Ave., Suite A
Roselle, IL 60172

p: 972.881.9797 e: info@optipure.net
www.optipurewater.com