

OptiPure

Model: **QTC2+MP**
Part #: 160-52045

Snapshot

The OptiPure QTC2+MP Multi-Point Filtration System provides a combination of filters to meet the requirements of different equipment applications including fountain beverages, ice and coffee. The system includes four Qwik-Twist cartridges. The first cartridge is a 5-micron QT sediment pre-filter, followed by two primary cartridges that reduce sediment down to 0.5-microns and reduces chlorine, taste & odor at a flow rate of 4.5 gpm for 45,000-gallons. The fourth cartridge is a secondary filter that provides added scale protection with IsoNet® for ice machines and coffee brewers.

System Benefits

- Dual system outlets provide primary filtration for cold beverages and additional secondary filtration for ice machines and coffee brewers.
- Utilizes Qwik-Twist cartridges that make changing filters quick, easy and sanitary.
- Primary filtration protects against dirt, rust and other debris down to 0.5-microns.
- Primary filtration makes water taste great and protects equipment against corrosive chlorine.
- Secondary filter provides the added protection of IsoNet®, OptiPure's patented scale inhibiting technology, which helps protect equipment against scale and corrosion for the rated capacity of the system.
- Additional 5-micron pre-filter provides further protection on water supplies with excessive sediment.
- Improves the quality and consistency of cold and hot beverages and of ice.
- Reduces maintenance frequency and cost, and extends equipment life.
- Compact design, heavy duty mounting bracket and full-flow inlet and outlet shut-off valve makes installation simple.
- Built-in pressure gauge allows visual monitoring of when filters need to be changed.

ITEM #: _____ QTY: _____

JOB NAME/NUMBER: _____



Application

COMBINATION APPLICATIONS

Fountain and Cold Beverage

Ice Machines

Coffee Brewers

Installation Tips

- Feed-water connection to system should be COLD only.
- Do not exceed system specifications for temperature and pressure.
- Provide a dedicated water line of at least 3/8" I.D. to the unit for consistent flow and pressure to the system.
- Allow 3" clearance below system for filter cartridge removal and replacement.
- Detailed installation, operation and maintenance manual are included with each system.

OptiPure

Model: **QTC2+MP**
Part #: 160-52045

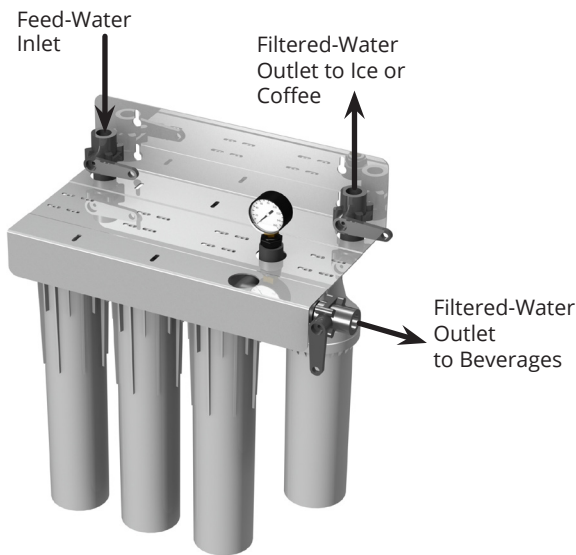
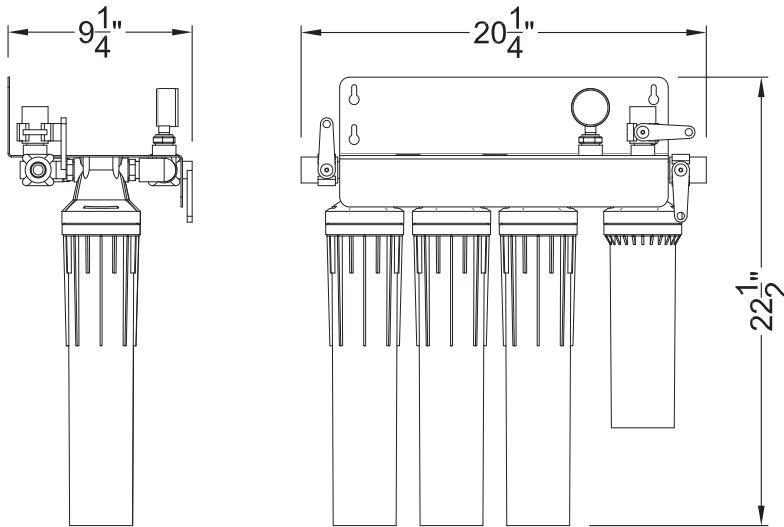

WARNING:
Cancer and Reproductive Harm -
www.P65Warnings.ca.gov

► Warranty

All system components and assembly except for filter cartridges, separation membranes, permeate pumps, electric motors, diaphragm pumps, and rotary vane pumps shall be warranted against defects in workmanship for a period of 60 months from the date of original shipment. For complete warranty information, contact OptiPure customer service or go to www.optipurewater.com.

Dealer/Distributor Info:

► Specifications

System	
Dimensions (Height x Width x Depth, Inches)	22.5"h x 20.3"w x 9.3"d
Connection - Inlet & Outlet	1/2" FNPT
Operating Pressure Range	10 - 125 psi (0.7 - 8.6 bar)
Inlet Water Temperature Range	35° - 100° F (2° - 38° C)
Shipping Weight	25 lbs.
Performance	
Chlorine, Taste and Odor Reduction Capacity	45,000 gals. (170,344 L)
Service Flow Rate	4.5 gpm (17 lpm)
Sediment Reduction	0.5 microns (nominal)
Scale & Corrosion Inhibitor	IsoNet® (100 grams)

► Replacement Cartridges

Model	Description	Part Number	Qty
S5-Q	Pre-Filter	300-05802	1
XTO-Q	Membrane	300-05840	2
PTS-Q	Post-Filter	300-05805	1

► Options

Model	Description	Part Number
Flush Valve Kit	QT Flush Valve Kit	160-52912

It is recommended that pre/post-filters and mineral addition cartridges are changed every 6 months, when capacity is reached or when feedwater pressure or flow becomes inadequate.

Membrane life varies depending on feedwater conditions and pre-filter maintenance. It is 12-18 months under typical conditions, but it can be as long as 3-5 years.

This product is for commercial use only and must be installed and maintained according to manufacturer's guidelines.

Do not use on water that is microbiologically unsafe or of unknown quality without adequate disinfection before or after the system.

OptiPure, A Division of Aquion, Inc.

101 S. Gary Ave., Suite A
Roselle, IL 60172

p: 972.881.9797 e: info@optipure.net
www.optipurewater.com