

OptiPure

Model: **QT5-1**
Part #: 160-52075

ITEM #: _____ QTY: _____
JOB NAME/NUMBER _____

Snapshot

The QT5-1 is a single-cartridge water treatment system with a 5" Qwik-Twist cartridge that reduces sediment down to 1-micron and reduces chlorine, taste & odor at a flow rate of 0.75 gpm for 6,000-gallons.

System Benefits

- Improves quality and consistency of cold and hot beverages.
- Reduces maintenance frequency and cost, and extends equipment life.
- Gradient-density sediment filtration protects against dirt, rust and other debris down to 1-micron.
- High-capacity activated-carbon filtration makes water taste great and protects equipment against corrosive chlorine.
- Sturdy mounting bracket and full-flow inlet shut-off valve simplify installation.
- Inlet shut-off valve makes filter replacement quick and simple.
- Utilizes Qwik-Twist cartridges that make changing filters quick, easy and sanitary.
- IAPMO certified to NSF/ANSI standard 42.



Application

FOUNTAIN BEVERAGES - Single carbonator.

COFFEE & TEA - Applications where water hardness is not a problem.

DRINKING WATER

Installation Tips

- Feed-water connection to system should be COLD only.
- Do not exceed system specifications for temperature and pressure.
- Allow 3" clearance below system for filter cartridge removal and replacement.
- Detailed installation, operation and maintenance manual included with each system.
- No activation procedure or flushing required for system to perform as specified.



OptiPure

Model: **QT5-1**
Part #: 160-52075

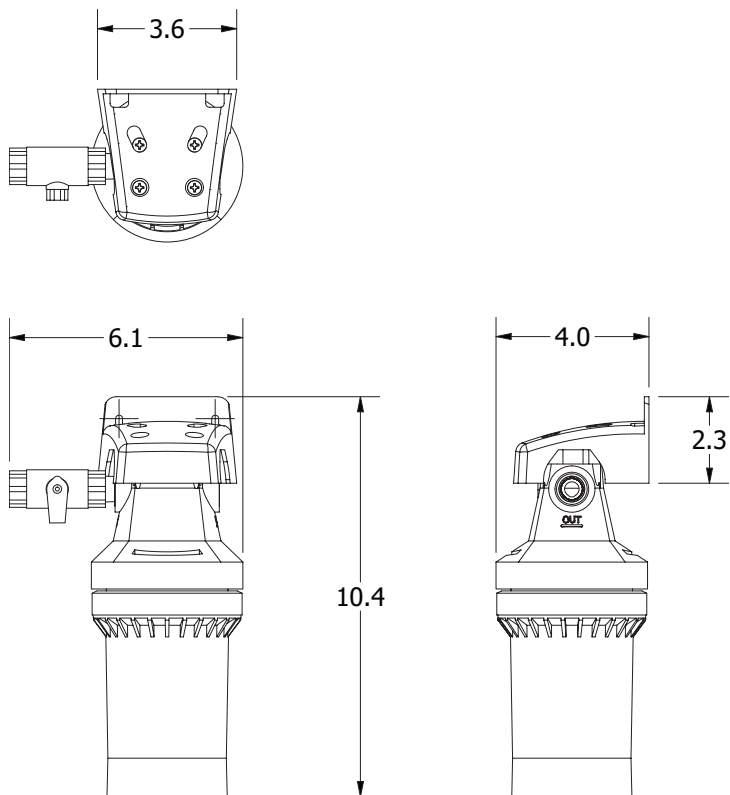

WARNING:
Cancer and Reproductive Harm -
www.P65Warnings.ca.gov



System certified by IAPMO R&T to NSF/ANSI Standard 42 for the reduction of chlorine, taste & odor.

Warranty

All system components and assembly except for filter cartridges, separation membranes, permeate pumps, electric motors, diaphragm pumps, and rotary vane pumps shall be warranted against defects in workmanship for a period of 60 months from the date of original shipment. For complete warranty information, contact OptiPure customer service or go to www.optipurewater.com.

Dealer/Distributor Info:

Specifications

System	
Dimensions (Height x Width x Depth, Inches)	10.4"h x 6.1"w x 4"d
Connection - Inlet & Outlet	3/8" FNPT
Operating Pressure Range	10 - 125 psi (0.7 - 8.6 bar)
Inlet Water Temperature Range	35° - 100° F (2° - 38° C)
Shipping Weight	4 lbs.
Performance	
Chlorine, Taste and Odor Reduction Capacity	6,000 gals. (22,712 L)
Service Flow Rate	0.75 gpm (2.85 lpm)
Sediment Reduction	1 micron (nominal)
Scale & Corrosion Inhibitor	N/A

Replacement Cartridge(s)

Model	Part Number	Qty
CTO-Q5	300-05803	1

Options

Model	Description	Part Number
Flush Valve Kit	QT Flush Valve Kit	160-52912

It is recommended that pre/post-filters and mineral addition cartridges are changed every 6 months, when capacity is reached or when feedwater pressure or flow becomes inadequate.

Membrane life varies depending on feedwater conditions and pre-filter maintenance. It is 12-18 months under typical conditions, but it can be as long as 3-5 years.

This product is for commercial use only and must be installed and maintained according to manufacturer's guidelines.

Do not use on water that is microbiologically unsafe or of unknown quality without adequate disinfection before or after the system.

OptiPure, A Division of Aquion, Inc.

101 S. Gary Ave., Suite A
Roselle, IL 60172

p: 972.881.9797 e: info@optipure.net
www.optipurewater.com