

OptiPure

Model: **BWS100/2**
Part #: 164-00102

Snapshot

The OptiPure® **BWS100/2** is a Blended Water System that utilizes Reverse Osmosis (RO) to remove >97% of the Total Dissolved Solids (TDS) from water which can be precisely blended with filtered water to a user-determined TDS level. The system operates at line pressure and can produce up to 100-gallons per day of optimal quality water. The system includes an integrated pre-filter which reduces sediment and chlorine and a final post-filter to assure beverage quality. The BWS100/2 also includes a hydropneumatic storage tank that holds up to 2.5-gallons to meet specific demand requirements. The compact design can be wall-mounted or installed under the counter and comes with tubing and fittings required for installation.

System Benefits

- Significantly reduces scale and corrosion problems related to high TDS, water hardness and chlorides.
- The system utilizes an integrated permeate pump in a unique hydraulic design that assures consistent production and blend accuracy.
- High capacity pre-filter takes out sediment and chlorine and protects the RO membrane.
- Compact, modular design utilizes installation under counters and in tight spaces.
- Three different mounting locations enables the water quality monitor to be easily viewed in any installation.
- Precision blending valve allows the user to accurately and precisely blend a calculated amount of filtered water with the RO product water.
- Digital before and after TDS meter for push-button monitoring of membrane performance and optimized water quality.
- Built-in pressure gauge allows visual monitoring of operating pressure.
- Non-electric design operates on available water pressure.
- All consumables are easy-to-change Qwik-Twist cartridges.
- Simple, easy-to-service and maintain design.



Application

Espresso
Coffee
Tea

Where high quality water and the ability to manage Total Dissolved Solids (TDS) level is desired.

Installation Tips

- Feed-water connection to system should be COLD only.
- Do not exceed system specifications for temperature and pressure.
- Provide a dedicated water line of at least 3/8" I.D. to the unit for consistent flow and pressure to the system.
- Allow 3" clearance below system for filter cartridge removal and replacement.
- Connect filtered water line to steam production connections only. Do not use for condenser water.
- Detailed installation, operation and maintenance manual included with each system.
- Mount the unit where it can be easily viewed and accessed.

OptiPure

Model: **BWS100/2**

Part #: 164-00102

► Specifications

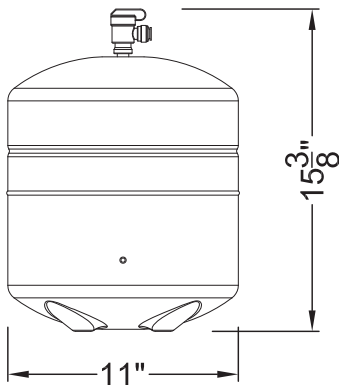
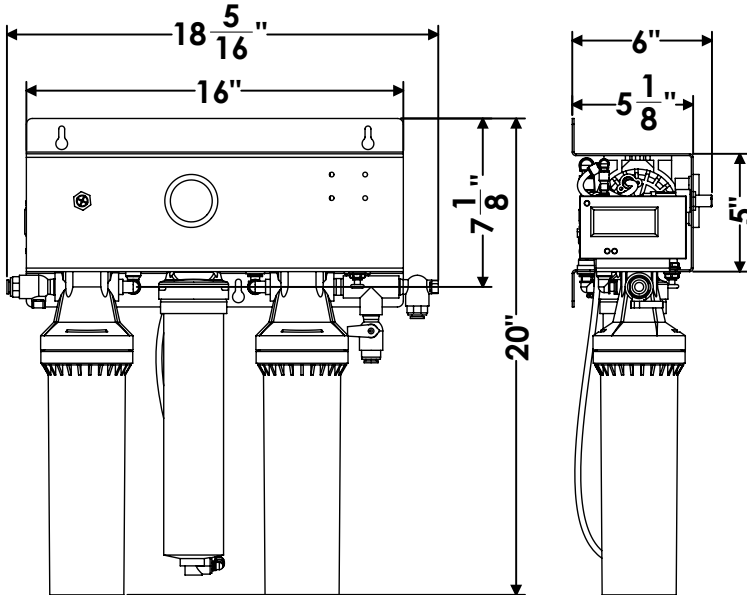

Feed-Water Chemistry

Feed TDS	Up to 1200 ppm
Feed pH	6-10 units
Hardness*	12 grains or less
Free Chlorine	<2 mg/l
Iron	0.1 mg/l max
Turbidity	0.05 NTU
Manganese	0.05 mg/l max
Hydrogen Sulfide	0.0 mg/l

*For water outside of these parameters call OptiPure technical service.



WARNING:
Cancer and Reproductive Harm -
www.P65Warnings.ca.gov.

System	
Dimensions - Processor	20"h x 18.3"w x 6"d
Dimensions - Tank	15.4"h x 11"dia.
Connection - Feedwater	3/8" Push Fit Tubing
Operating Pressure Range	60 - 85 psi (3.5 - 5.9 bar)
Inlet Water Temperature Range	40° - 100°F (4° - 38°C)
Shipping Weight	25 lbs.
Drain Connection	2.0 gpm Minimum Flow
Performance	
Typical TDS Rejection	>97%
Product Water Production (at 77°F, 60 psi Net Operating Pressure) Production rate is strictly dependent on feed water temperature and pressure.	70.0 gals./day 2.9 gals./hr
Blended Water Production	100 gpd
Storage Tank Capacity	2.5 gals.

► Replacement Media

Model	Description	Part Number	Qty
CTO-Q10	Pre/Post-Filter	300-05828	2
AMS-QT10	Membrane	204-52810	1

► Options

Model	Description	Part Number
PRV	Pressure Reducing Valve	164-89938
BPS100	Booster Pump Assembly	164-85010
ByPass Kit	BWS100 ByPass Kit	160-52890

It is recommended that pre/post-filters and mineral addition cartridges are changed every 6 months, when capacity is reached or when feedwater pressure or flow becomes inadequate.

Membrane life varies depending on feedwater conditions and pre-filter maintenance. It is 12-18 months under typical conditions, but it can be as long as 3-5 years.

This product is for commercial use only and must be installed and maintained according to manufacturer's guidelines.

Do not use on water that is microbiologically unsafe or of unknown quality without adequate disinfection before or after the system.

OptiPure, A Division of Aquion, Inc.

101 S. Gary Ave., Suite A
Roselle, IL 60172

p: 972.881.9797 e: info@optipure.net
www.optipurewater.com

► Warranty

All system components and assembly except for filter cartridges, separation membranes, permeate pumps, electric motors, diaphragm pumps, and rotary vane pumps shall be warranted against defects in workmanship for a period of 60 months from the date of original shipment. For complete warranty information, contact OptiPure customer service or go to www.optipurewater.com.

Dealer/Distributor Info: