

OptiPure

Model: **OP175/50**
Part #: 164-00225

ITEM #: _____ QTY: _____

JOB NAME/NUMBER: _____

Snapshot

The OptiPure® OP175/50 utilizes Reverse Osmosis (RO) to remove >97% of the Total Dissolved Solids (TDS) from water. Then, a balance of minerals is dissolved into the RO water to provide optimized water with desirable TDS for recommended applications. The system operates at line pressure and can produce up to 175-gallons per day of optimal quality water. The OP175 processor can be wall-mounted or installed under the counter and includes integrated pre-filtration with particulate and chlorine reduction. System includes a built-in full system bypass valve. System also includes a 50-gallon atmospheric storage tank with a top-mounted variable-flow repressurization system and a sub-micron air breather, hose, tubing and fittings required for installation.



System Benefits

- Significantly reduces scale and corrosion problems related to high TDS, water hardness and chlorides.
- Ideal for all applications where TDS, hardness and chloride reduction are necessary to meet manufacturer's warranty requirements.
- Integrated mineral-addition cartridge provides TDS needed for conductivity sensors and optimal mineral content for all equipment applications.
- High capacity Pre-filters take out sediment and chlorine and protect the RO membrane.
- Digital before and after TDS meter for push-button monitoring of membrane performance and optimized water quality.
- Sample port allows quick and simple system checks and adjustments.
- Integrated system bypass valve eliminates service interruptions and down-time.
- All consumables are easy-to-change Qwik-Twist cartridges.
- Non-electric design operates on available water pressure.
- Simple, easy-to-install and service design.

Application

Any foodservice equipment where it is desirable to remove existing Total Dissolved Solids (TDS) and provide a consistent balance of buffered TDS.

Installation Tips

- Feed-water connection to system should be COLD only.
- Do not exceed system specifications for temperature and pressure.
- Provide a dedicated water line of at least 1/2" I.D. to the unit for consistent flow and pressure to the system.
- Allow 3" clearance below system for filter cartridge removal and replacement.
- Connect filtered water line to steam production connections only. Do not use for condenser water.
- Detailed installation, operation and maintenance manual are included with each system.

OptiPure

Water Processor Assembly

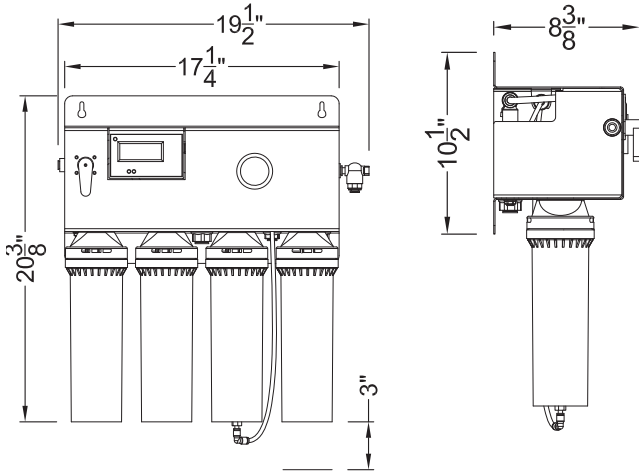

Storage Tank Assembly - 120V

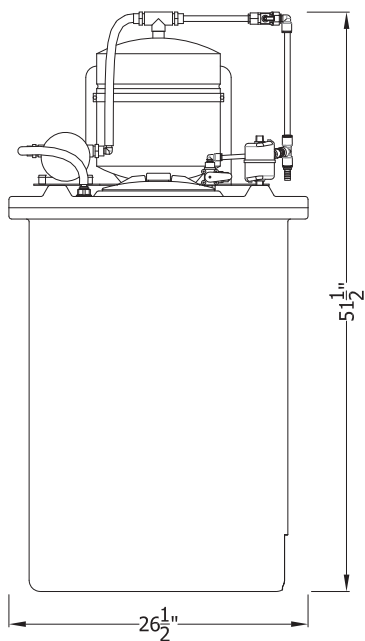

Feed-Water Chemistry

Feed TDS	Up to 1200 ppm
Feed pH	6-10 units
Hardness*	12 grains or less
Free Chlorine	<2 mg/l
Iron	0.1 mg/l max
Turbidity	0.05 NTU
Manganese	0.05 mg/l max
Hydrogen Sulfide	0.0 mg/l

*For water outside of these parameters call OptiPure technical service.



WARNING:
Cancer and Reproductive Harm -
www.P65Warnings.ca.gov.

Warranty

All system components and assembly except for filter cartridges, separation membranes, permeate pumps, electric motors, diaphragm pumps, and rotary vane pumps shall be warranted against defects in workmanship for a period of 60 months from the date of original shipment. For complete warranty information, contact OptiPure customer service or go to www.optipurewater.com.

Dealer/Distributor Info:

Model: **OP175/50**
Part #: 164-00225

Specifications

System

Dimensions - Processor	20.4"h x 19.5"w x 8.4"d
Dimensions - Tank	51.5"h x 26.5"dia.
Connection - Feedwater	3/8" Push Fit Tubing
Operating Pressure Range	60 - 85 psi (4.1 - 5.9 bar)
Inlet Water Temperature Range	40° - 100°F (4° - 38°C)
Shipping Weight	25 lbs.
Drain Connection	2.0 gpm Minimum Flow
Power - Repressurization Pump	120V 60Hz 2 Amps

Performance

Typical TDS Rejection	>97%
Typical Optimized Water TDS	40 - 80 ppm
Product Water Production (at 77°F, 60 psi Net Operating Pressure) Production rate is strictly dependent on feed water temperature and pressure.	175+ gals./day 7.3 gals./hr 0.12 gpm

Replacement Media

Model	Description	Part Number	Qty
CTO-Q10	Pre-Filter	300-05828	2
AMS-QT15	Membrane	204-52820	1
MA-Q10	Post-Filter	300-05850	1

Options

Model	Description	Part Number
Air-Gap Kit	Approved Air-Gap Kit for Drain Line	164-89905
QTPT-1	CTO Post-Treatment	160-52120
BPA200	Booster Pump Assembly	164-85015
FXPT-11CR	Chloramine Reduction System	160-50011
PRV	Pressure Reducing Valve	164-89938
Remote Kit	Repressurization/Storage Tank Assembly remote kit	164-89116

It is recommended that pre/post-filters and mineral addition cartridges are changed every 6 months, when capacity is reached or when feedwater pressure or flow becomes inadequate.

Membrane life varies depending on feedwater conditions and pre-filter maintenance. It is 12-18 months under typical conditions, but it can be as long as 3-5 years.

This product is for commercial use only and must be installed and maintained according to manufacturer's guidelines.

Do not use on water that is microbiologically unsafe or of unknown quality without adequate disinfection before or after the system.

OptiPure, A Division of Aquion, Inc.
101 S. Gary Ave., Suite A
Roselle, IL 60172
p: 972.881.9797 e: info@optipure.net
www.optipurewater.com