

OptiPure

Model: **OP70/16**
Part #: 164-01016

Snapshot

The OptiPure® OP70/16 utilizes Reverse Osmosis (RO) to remove >97% of the Total Dissolved Solids (TDS) from water. Then, a balance of minerals is dissolved into the RO water to provide optimized water with desirable TDS for recommended applications. The system operates at line pressure and can produce up to 70-gallons per day of optimal quality water. The compact OP70 processor can be wall-mounted or installed under the counter and includes integrated pre-filtration with particulate and chlorine reduction. System includes a built-in full system bypass valve. System also includes a 16-gallon hydropneumatic storage tank and hose, tubing and fittings required for installation.

System Benefits

- Significantly reduces scale and corrosion problems related to high TDS, water hardness and chlorides.
- Ideal for combi and steam oven applications where TDS, hardness and chloride reduction are necessary to meet manufacturer's warranty requirements.
- Integrated mineral-addition cartridge provides TDS needed for conductivity sensors and optimal mineral content for steam equipment applications.
- High capacity pre-filter takes out sediment and chlorine and protects the RO membrane.
- Sealed hydropneumatic storage tank provides needed capacity and delivers pressurized water to downstream equipment.
- Integrated system bypass valve eliminates costly service interruptions and down-time.
- Compact, modular design utilizes installation under counters and in tight spaces.
- Non-electric design operates on available water pressure.
- Simple, easy-to-install and service design.



Application

Combi Ovens
Steamers
Proofers & Humidifiers

Installation Tips

- Feed-water connection to system should be COLD only.
- Do not exceed system specifications for temperature and pressure.
- Provide a dedicated water line of at least 3/8" I.D. to the unit for consistent flow and pressure to the system.
- Allow 3" clearance below system for filter cartridge removal and replacement.
- Detailed installation, operation and maintenance manual are included with each system.

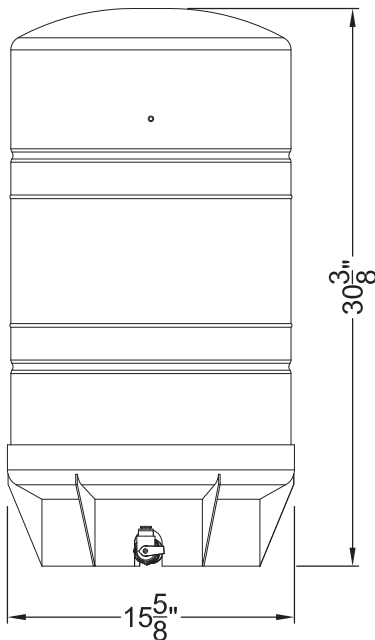
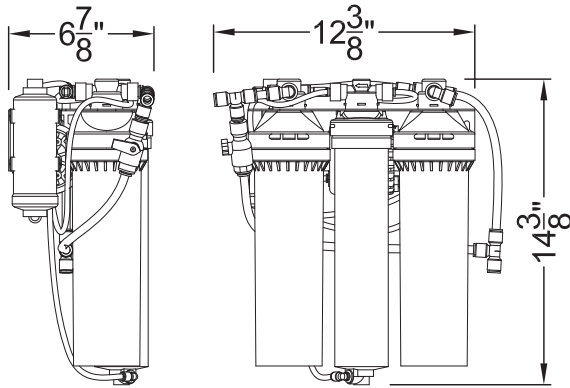

Feed-Water Chemistry

Feed TDS	Up to 1200 ppm
Feed pH	6-10 units
Hardness*	12 grains or less
Free Chlorine	<2 mg/l
Iron	0.1 mg/l max
Turbidity	0.05 NTU
Manganese	0.05 mg/l max
Hydrogen Sulfide	0.0 mg/l

*For water outside of these parameters call OptiPure technical service.



WARNING:
Cancer and Reproductive Harm -
www.P65Warnings.ca.gov.

► Specifications

System	
Dimensions - Processor	14.4"h x 12.4"w x 6.9"d
Dimensions - Tank	30.4"h x 15.6"dia.
Connection - Feedwater	3/8" Push Fit Tubing
Operating Pressure Range	60 - 85 psi (3.5 - 5.9 bar)
Inlet Water Temperature Range	40° - 100°F (4° - 38°C)
Shipping Weight	30 lbs.
Drain Connection	2.0 gpm Minimum Flow
Performance	
Typical TDS Rejection	>97%
Product Water Production (at 77°F, 60 psi Net Operating Pressure) Production rate is strictly dependent on feed water temperature and pressure.	70.0 gals./day 2.9 gals./hr
Storage Tank Capacity	16 gals.

► Replacement Media

Model	Description	Part Number	Qty
CTO-Q10	Pre/Post-Filter	300-05828	2
AMS-QT10	Membrane	204-52810	1
ILMA-6.14	Mineral Addition	252-70260	1

► Options

Model	Description	Part Number
PRV	Pressure Reducing Valve	164-89938
BPS100	Booster Pump Assembly	164-85010

It is recommended that pre/post-filters and mineral addition cartridges are changed every 6 months, when capacity is reached or when feedwater pressure or flow becomes inadequate.

Membrane life varies depending on feedwater conditions and pre-filter maintenance. It is 12-18 months under typical conditions, but it can be as long as 3-5 years.

This product is for commercial use only and must be installed and maintained according to manufacturer's guidelines.

Do not use on water that is microbiologically unsafe or of unknown quality without adequate disinfection before or after the system.

OptiPure, A Division of Aquion, Inc.
101 S. Gary Ave., Suite A
Roselle, IL 60172
p: 972.881.9797 e: info@optipure.net
www.optipurewater.com

► Warranty

All system components and assembly except for filter cartridges, separation membranes, permeate pumps, electric motors, diaphragm pumps, and rotary vane pumps shall be warranted against defects in workmanship for a period of 60 months from the date of original shipment. For complete warranty information, contact OptiPure customer service or go to www.optipurewater.com.

Dealer/Distributor Info: