

OptiPure

Model: **OPS70/2**
Part #: 164-01202

Snapshot

The OptiPure® OPS70/2 utilizes Reverse Osmosis (RO) to remove >97% of the Total Dissolved Solids (TDS) from water. Then, a balance of minerals is dissolved into the RO water to provide optimized water with desirable TDS for recommended applications. The system can produce up to 70-gallons per day operating at line-pressure and includes an integrated pre-filter which reduces sediment and chlorine. The OPS70/2 includes a hydropneumatic storage tank that holds up to 2.5-gallons to meet specific demand requirements. The system also has a built-in manual bypass valve. The compact design can be wall-mounted or installed under the counter and comes with tubing and fittings required for installation.

System Benefits

- Significantly reduces scale and corrosion problems related to high TDS, water hardness and chlorides.
- Ideal for combi and steam oven applications where TDS, hardness and chloride reduction are necessary to meet manufacturer's warranty requirements.
- Integrated mineral-addition cartridge provides TDS needed for conductivity sensors and optimal mineral content for steam equipment applications.
- High capacity pre-filter takes out sediment and chlorine and protects the RO membrane.
- Sealed hydropneumatic storage tank provides needed capacity and delivers pressurized water to downstream equipment.
- Optimized water line to equipment is 1/2" ID hose. A 3/4" Garden Hose Thread (GHT) connector is provided for connection to equipment when applicable.
- Integrated system bypass valve eliminates costly service interruptions and down-time.
- Compact, modular design utilizes installation under counters and in tight spaces.
- Non-electric design operates on available water pressure.
- Simple, easy-to-install and service design.

ITEM #: _____ QTY: _____

JOB NAME/NUMBER: _____



Application

Combi Ovens
Steam Ovens
Proofers and Humidifiers

Installation Tips

- Feed-water connection to system should be COLD only.
- Do not exceed system specifications for temperature and pressure.
- Provide a dedicated feed water supply of at least 3/8" I.D.
- For use with steam generation only. Do not use for condensate or wash-water.
- Allow 3" clearance below system for filter cartridge removal and replacement.
- Detailed, illustrated installation guide is included with each system.

OptiPure

Model: **OPS70/2**
Part #: 164-01202

► Specifications

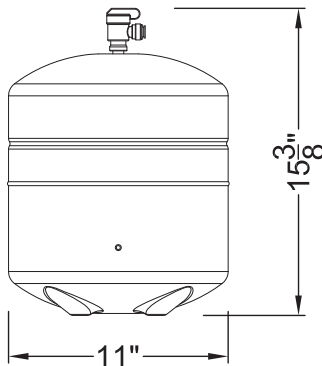
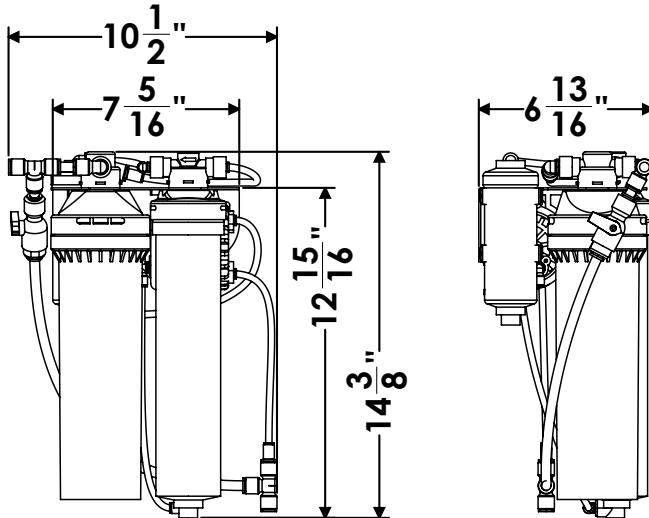

Feed-Water Chemistry

Feed TDS	Up to 1200 ppm
Feed pH	6-10 units
Hardness*	12 grains or less
Free Chlorine	<2 mg/l
Iron	0.1 mg/l max
Turbidity	0.05 NTU
Manganese	0.05 mg/l max
Hydrogen Sulfide	0.0 mg/l

*For water outside of these parameters call OptiPure technical service.



System	
Dimensions - Processor	14.4"h x 10.5"w x 7"d
Dimensions - Tank	15.4"h x 11"dia.
Connection - Feedwater	3/8" Push Fit Tubing
Operating Pressure Range	60 - 85 psi at 0.5 gpm (3.5 - 5.9 bar)
Inlet Water Temperature Range	40° - 100°F (4° - 38°C)
Shipping Weight	25 lbs.
Drain Connection	2.0 gpm Minimum Flow
Performance	
Typical TDS Rejection	>97%
Product Water Production (at 77°F, 60 psi Net Operating Pressure) Production rate is strictly dependent on feed water temperature and pressure.	70.0 gals./day 2.9 gals./hr
Storage Tank Capacity	2.5 gals.

► Replacement Media

Model	Description	Part Number	Qty
CTO-Q10	Pre-Filter	300-05828	1
AMS-QT10	Membrane	204-52810	1
ILMA-6.14	Mineral Addition	252-70260	1

► Options

Model	Description	Part Number
PRV	Pressure Reducing Valve	164-89938
BPS100	Booster Pump Assembly	164-85010

It is recommended that pre/post-filters and mineral addition cartridges are changed every 6 months, when capacity is reached or when feedwater pressure or flow becomes inadequate.

Membrane life varies depending on feed water conditions and pre-filter maintenance. It is recommended to replace the membrane every 18 months.

This product is for commercial use only and must be installed and maintained according to manufacturer's guidelines.

Do not use on water that is microbiologically unsafe or of unknown quality without adequate disinfection before or after the system.

► Warranty

All system components and assembly except for filter cartridges, separation membranes, permeate pumps, electric motors, diaphragm pumps, and rotary vane pumps shall be warranted against defects in workmanship for a period of 60 months from the date of original shipment. For complete warranty information, contact OptiPure customer service or go to www.optipurewater.com.

Dealer/Distributor Info:

OptiPure, A Division of Aquion, Inc.
101 S. Gary Ave., Suite A
Roselle, IL 60172
p: 972.881.9797 e: info@optipure.net
www.optipurewater.com