

Water Processor
- 120 VAC / 6 Watts

9" Deep

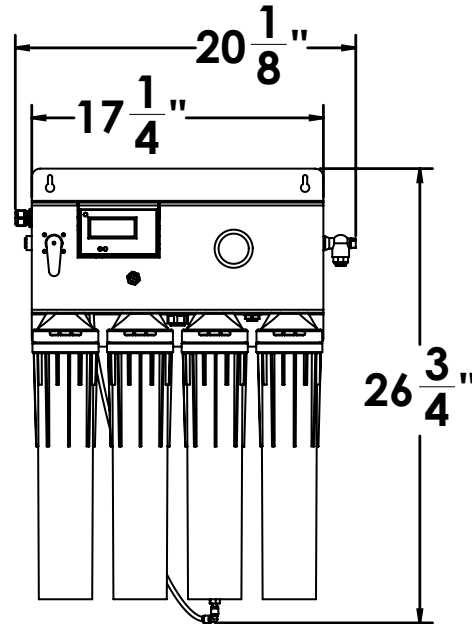

Storage Tank Assembly
- 120 VAC / 2 Amps

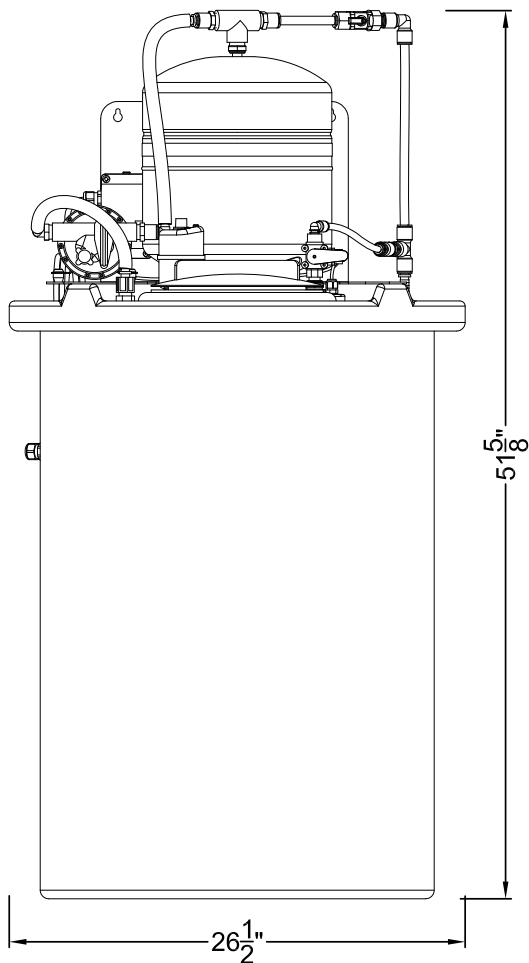

► Pre-Installation Requirements

System Placement

- The Water Processor is heavy and must be mounted where it is well-supported, using wall studs, or on a $\frac{3}{4}$ "-thick panel of plywood anchored to the wall studs.
- The Storage Tank Assembly with Repressurization Pump must be located within 5 feet of the water processor. The floor must be smooth, clean and free of sharp objects that could puncture the bottom of the tank.

Feed water connection

- Adequate flow and pressure to the unit is critical. Run a $\frac{1}{2}$ " cold water line with a full flow ball valve with $\frac{1}{2}$ " FPT (Female Pipe Thread) connection to the vicinity of the unit. Feed water pressure should be between 50-80 psi.
- Backflow Device – Any backflow devices required by local or state code must be supplied prior to installation.

Electrical

- The Water Processor and the Repressurization Pump each require a power outlet (2 sockets total). The power outlets should be located within 4 feet of the units.
- Water Processor – 120 VAC / 60 Hz / 6 Watts
- Repressurization Pump – 120 VAC / 60 Hz / 2 Amps

Drain

- A drain with a minimum flow rate of 2 gpm should be located within 6 feet of the unit. Drain line from processor is $\frac{1}{4}$ " tubing. Comply with local plumbing codes – most require the installation of an approved air gap.

OptiPure, A Division of Aquion, Inc.

101 S. Gary Ave., Suite A
Roselle, IL 60172

p: 972.881.9797 e: info@optipure.net

www.optipurewater.com