

OptiPure

Snapshot

The OptiPure® OP350/50 HF utilizes Reverse Osmosis (RO) to remove >97% of the Total Dissolved Solids (TDS) from water. Then, a balance of minerals is dissolved into the RO water to provide optimized water with desirable TDS for recommended applications. The system operates at line pressure and can produce up to 350-gallons per day of optimal quality water for applications where TDS reduction or the removal of the majority of hardness minerals is required. This complete system includes integrated pre-filtration with particulate and chlorine reduction, reverse osmosis, and mineral addition, in a space saving, wall-mounted design. Adjustable reject flow control allows precise adjustment of product/reject ratio. A built-in full system bypass valve and sample port assures no service interruption and simplifies routine maintenance. Also included is a 50-gallon atmospheric storage tank (with a sub-micron air breather) with a 1hp floor-mounted repressurization pump, a 16-gallon buffer tank assembly and a 1/2" outlet that allows for high-flow applications. Hose, tubing and fittings required for installation are included.

System Benefits

- Significantly reduces scale and corrosion problems related to high TDS, water hardness and chlorides.
- High flow delivery system for high demand applications.
- Digital before and after TDS meter for push-button monitoring of membrane performance and optimized water quality.
- Adjustable reject flow control minimizes water use due to seasonal fluctuations in water temperature.
- Sample port enables quick and simple system checks and adjustments.
- Built-in pressure gauge allows visual monitoring of operating pressure.
- Integrated system bypass valve eliminates costly service interruptions and down-time.
- All consumables are easy-to-change Qwik-Twist cartridges.
- Integrated mineral-addition cartridge provides TDS needed for conductivity sensors and optimal mineral content for all equipment applications.
- High capacity Pre-filters take out sediment and chlorine and protect the RO membrane.

Model: **OP350/50 HF**
Part #: 164-14451

ITEM #: _____ QTY: _____

JOB NAME/NUMBER: _____



Application

Any foodservice equipment where it is desirable to remove existing Total Dissolved Solids (TDS) and provide a consistent balance of buffered TDS. Designed for multiple point-of-use applications where up to 10.0 gpm is required.

Installation Tips

- Feed-water connection to system should be COLD only.
- Do not exceed system specifications for temperature and pressure.
- Provide a dedicated 1/2" water line to the unit to consistent flow and pressure to the system.
- Allow 3" clearance below system for filter cartridge removal and replacement.
- Connect filtered water line to steam production connections only. Do not use for condenser water.
- Detailed installation, operation and maintenance manual is included with each system.
- Mount the unit where it can be easily viewed and accessed.

OptiPure

Model: **OP350/50 HF**
Part #: 164-14451

► Specifications

System	
Dimensions - Processor	26.8"h x 20.1"w x 8.4"d
Dimensions - Storage Tank	39.4"h x 26.5" dia.
Dimensions - Buffer Tank	30.4"h x 15.6" dia.
Connection - Feedwater	3/8" Push Fit Tubing
Operating Pressure Range	60 - 85 psi (4.1 - 5.9 bar)
Inlet Water Temperature Range	40° - 100°F (4° - 38°C)
Shipping Weight	100 lbs.
Drain Connection	2.0 gpm Minimum Flow
Power - Water Processor	120V 60Hz 6W
Power - Repressurization Pump	120V 60Hz 10 Amps
Performance	
Typical TDS Rejection	>97%
Product Water Production (at 77°F, 60 psi Net Operating Pressure) Production rate is strictly dependent on feed water temperature and pressure.	350.0 gals./day 14.6 gals./hr 0.25 gpm

► Replacement Media

Model	Description	Part Number	Qty
CTO-Q	Pre-Filter	300-05830	2
AMS-QT	Membrane	204-53040	1
MA-Q15	Post-Filter	300-05855	1

► Options

Model	Description	Part Number
Air-Gap Kit	Approved Air-Gap Kit for Drain Line	164-89905
QTPT-1	CTO Post-Treatment	160-52120
BPS-QT	Feed Water Booster Pump	164-85020
FXPT-11CR	Chloramine Reduction System	160-50011
PRV	Pressure Reducing Valve	164-89938

It is recommended that pre/post-filters and mineral addition cartridges are changed every 6 months, when capacity is reached or when feedwater pressure or flow becomes inadequate.

Membrane life varies depending on feedwater conditions and pre-filter maintenance. It is 12-18 months under typical conditions, but it can be as long as 3-5 years.

This product is for commercial use only and must be installed and maintained according to manufacturer's guidelines.

Do not use on water that is microbiologically unsafe or of unknown quality without adequate disinfection before or after the system.

OptiPure, A Division of Aquion, Inc.
101 S. Gary Ave., Suite A
Roselle, IL 60172
p: 972.881.9797 e: info@optipure.net
www.optipurewater.com

Water Processor Assembly - 120V

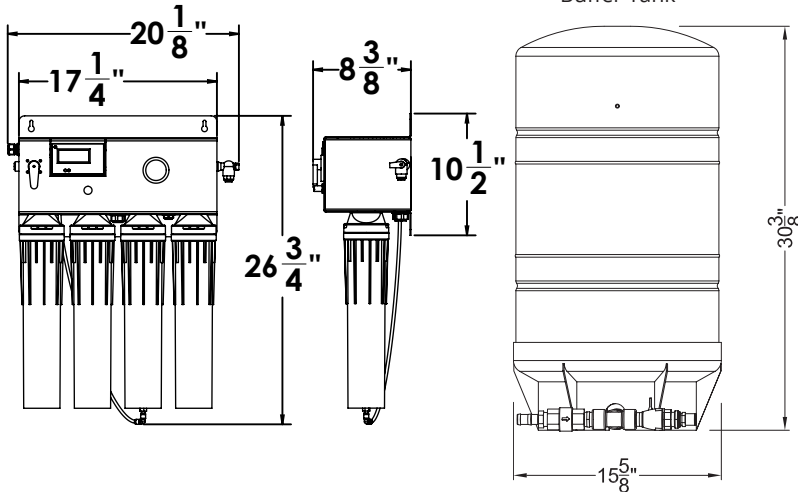

Storage Tank Assembly

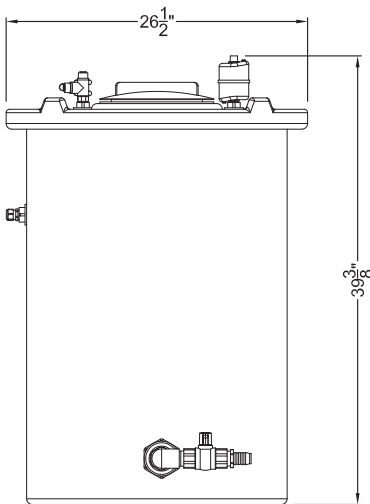

Repressurization Pump - 120V

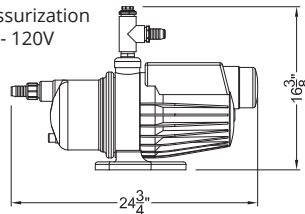

Feed-Water Chemistry

Feed TDS	Up to 1200 ppm
Feed pH	6-10 units
Hardness*	12 grains or less
Free Chlorine	<2 mg/l
Iron	0.1 mg/l max
Turbidity	0.05 NTU
Manganese	0.05 mg/l max
Hydrogen Sulfide	0.0 mg/l

*For water outside of these parameters call OptiPure technical service.



WARNING:
Cancer and Reproductive Harm -
www.P65Warnings.ca.gov.

► Warranty

All system components and assembly except for filter cartridges, separation membranes, permeate pumps, electric motors, diaphragm pumps, and rotary vane pumps shall be warranted against defects in workmanship for a period of 60 months from the date of original shipment. For complete warranty information, contact OptiPure customer service or go to www.optipurewater.com.

Dealer/Distributor Info:

OptiPure

Model: **OP350/50 HF**
Part #: 164-14451

Installation Diagram

