

OptiPure

Model: **OS.64**
Part #: 165-03064

Snapshot

The OptiSoft Water Softener Model **OS.64** is an ion-exchange water softener that is designed to remove up to 64,000 grains of calcium and magnesium hardness minerals at a service flow rate of up to 10-gallons per minute before regenerating. The system meters actual water usage to initiate regeneration. The softener valve has 1" inlet/outlet NPT connections and includes an integrated manual bypass valve. A digital display control board with push-button adjustments simplifies setup and user interface. The polyethylene brine tank holds up to 300 lbs. of salt and includes a safety overflow.

System Benefits

- High Flow 1" softener valve.
- Metered regeneration maximizes efficiency and minimizes waste.
- Push-button digital control panel make installation and service simple.
- System can remove or reduce up to 5 ppm of dissolved iron.
- Includes built-in emergency bypass valve.
- Brine tank salt bridge assures consistent brine and regeneration.
- Brine tank safety valve guards against tank overflow.

ITEM #: _____ QTY: _____
JOB NAME/NUMBER _____



Application

Any application requiring hardness and iron removal.

Pre-treatment for OptiPure RO Systems where hardness reduction is required.

Installation Tips

- Feed-water connection to the system should be COLD only.
- Do not exceed system specifications for temperature and pressure.
- Protect from freezing, system should never be exposed to temperatures below 35° F (2° C).
- Installation and use must comply with all state and local plumbing codes.



Model: **OS.64**
Part #: 165-03064

► Specifications

System	
Softener Tank Dimensions (Height x Diameter, Inches)	59" h x 12" dia.
Brine Tank Dimensions (Height x Diameter, Inches)	33" h x 18.8" dia.
Connection - Inlet & Outlet	1" NPT
Cold Water Operating Pressure Range	20 - 125 psi 1.4 - 8.6 bar)
Inlet Water Temperature Range	40° - 110° F (4° - 38° C)
Shipping Weight	lbs.
Electrical Connection	120V 60Hz 0.5 Amp
Performance	
Nominal Hardness Reduction <small>Performance depends on operating conditions and water chemistry.</small>	30,000 - 64,000 grains (10 - 20 lbs. salt setting)
Service Flow Rate	10.0 gpm (38.0 lpm)
Brine Tank Capacity (Salt)	77 lbs. (35 kg)

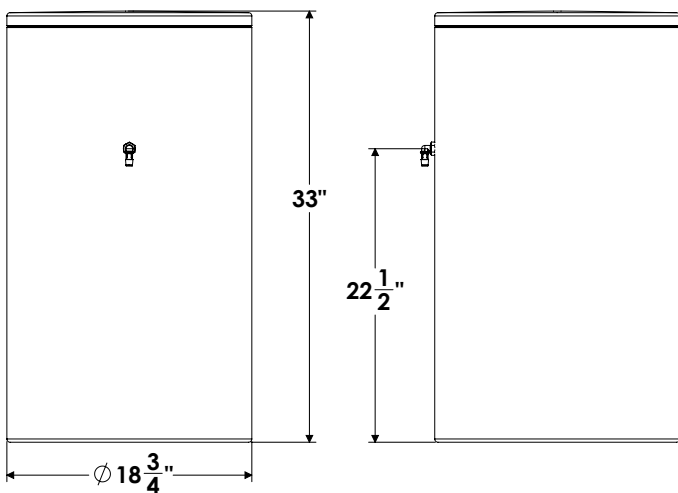
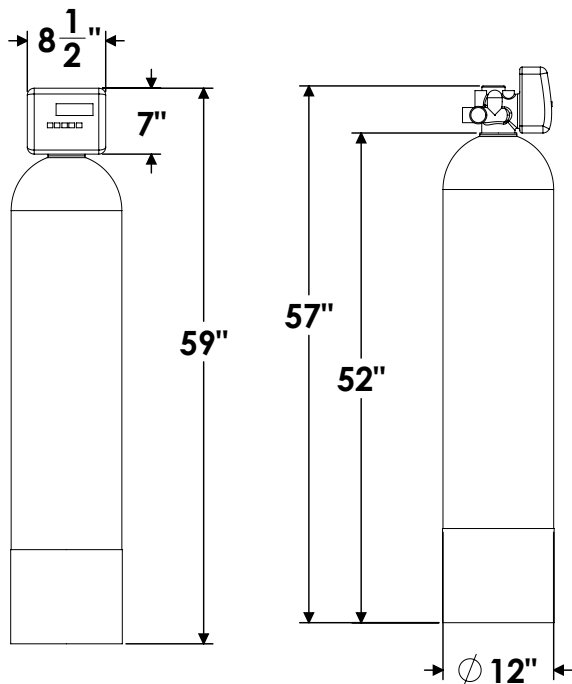

WARNING:
Cancer and Reproductive Harm -
www.P65Warnings.ca.gov.

► Warranty

Systems have a 1 year warranty against defects in material and workmanship from the date of original shipment. For complete warranty information, contact OptiPure customer service or go to www.optipurewater.com.

Dealer/Distributor Info:

► Options

Model	Description	Part Number
Hardness Test Kit	H2O Express Test Kit	180-80120

This product is for commercial use only and must be installed and maintained according to manufacturer's guidelines.

Do not use on water that is microbiologically unsafe or of unknown quality without adequate disinfection before or after the system.

OptiPure, A Division of Aquion, Inc.

101 S. Gary Ave., Suite A
Roselle, IL 60172

p: 972.881.9797 e: info@optipure.net
www.optipurewater.com