

OptiPure

Model: **QTC-2+**
Part #: 170-51007

Snapshot

The QTC-2+ is a triple-cartridge water treatment system with three 15" Qwik-Twist cartridges, parallel-plumbed, that reduces sediment down to 0.5-microns, and reduces chlorine, taste & odor at a flow rate of 4.5 gpm for 45,000-gallons. The system includes a 5-micron pre-filter for added protection on water supplies with excessive dirt and sediment. The system also reduces turbidity and health-related contaminants such as cysts.

System Benefits

- Reduces maintenance frequency and cost, and extends equipment life.
- Gradient-density sediment filtration protects against dirt, rust and other debris.
- High-capacity activated-carbon filtration makes water taste great and protects equipment against corrosive chlorine.
- Additional 5-micron pre-filter provides further protection on water supplies with excessive sediment.
- New manifold design provides fewer possible leak points.
- Sturdy, powder-coated mounting bracket and multi-function valve simplify installation.
- Multi-function valve provides:
 - * Shutoff valve for quick and simple filter replacements
 - * System bypass valve for easy system maintenance
 - * Flush port to flush cartridges after installation
- Built-in pressure gauge allows visual monitoring of when filters need to be changed.
- Utilizes Qwik-Twist cartridges that make changing filters quick, easy and sanitary.



ITEM #: _____ QTY: _____

JOB NAME/NUMBER _____

Application

FOUNTAIN BEVERAGES - One or two carbonators. Includes QT pre-filter for water supplies with high turbidity levels.

Installation Tips

- Feed-water connection to system should be COLD only.
- Do not exceed system specifications for temperature and pressure.
- Allow 3" clearance below system for filter cartridge removal and replacement.
- Detailed installation, operation and maintenance manual included with each system.
- No activation procedure or flushing required for system to perform as specified.

OptiPure

Model: **QTC-2+**
Part #: 170-51007

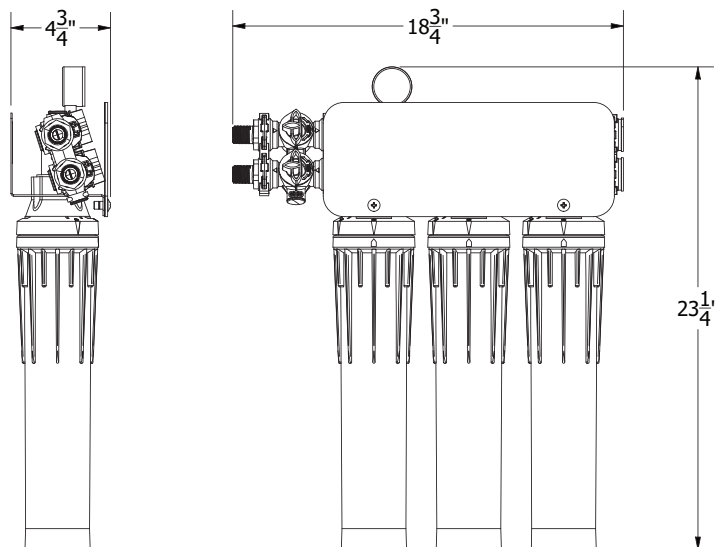
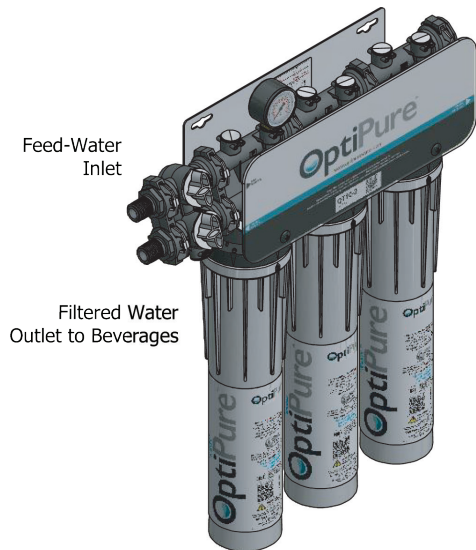

WARNING:
Cancer and Reproductive Harm -
www.P65Warnings.ca.gov.

► Warranty

All system components and assembly except for filter cartridges, separation membranes, permeate pumps, electric motors, diaphragm pumps, and rotary vane pumps shall be warranted against defects in workmanship for a period of 60 months from the date of original shipment. For complete warranty information, contact OptiPure customer service or go to www.optipurewater.com.

Dealer/Distributor Info:

► Specifications

System	
Dimensions (Height x Width x Depth, Inches)	23 1/4" x 18 3/4" x 4 3/4"
Connection - Inlet & Outlet	1/2" MNPT
Operating Pressure Range	10 - 125 psi (0.7 - 8.6 bar)
Inlet Water Temperature Range	35° - 100°F (2° - 38°C)
Shipping Weight	13 lbs.
Performance	
Chlorine, Taste and Odor Reduction Capacity	45,000 gals. (170,325 L)
Service Flow Rate	4.5 gpm (17.0 lpm)
Sediment Reduction	0.5 microns (nominal)
Reduces Harmful Cysts Reduces Turbidity	Yes

► Replacement Cartridge(s)

Model	Part Number	Qty
S5-Q	300-05802	1
XTO-Q	300-05840	2

► Options

Model	Description	Part Number
Flush Valve Kit	QT Flush Valve Kit	170-52912
Gauge Kit	QT Gauge Kit	170-52904

It is recommended that pre/post-filters and mineral addition cartridges are changed every 6 months, when capacity is reached or when feedwater pressure or flow becomes inadequate.

Membrane life varies depending on feedwater conditions and pre-filter maintenance. It is 12-18 months under typical conditions, but it can be as long as 3-5 years.

This product is for commercial use only and must be installed and maintained according to manufacturer's guidelines.

Do not use on water that is microbiologically unsafe or of unknown quality without adequate disinfection before or after the system.

OptiPure, A Division of Aquion, Inc.

101 S. Gary Ave., Suite A
Roselle, IL 60172

p: 972.881.9797 e: info@optipure.net
www.optipurewater.com