

ITEM #: _____ QTY: _____
JOB NAME/NUMBER _____

Snapshot

The QTI-4 is a quadruple-cartridge water treatment system with four 15" Qwik-Twist cartridges, parallel-plumbed, that reduces sediment down to 0.5-microns, and reduces chlorine, taste & odor at a flow rate of 9.0 gpm for 90,000-gallons. The system includes IsoNet®, OptiPure's patented scale inhibiting technology, which delivers consistent protection against the precipitation and accumulation of scale and provides a protective barrier to help guard against corrosion.

System Benefits

- IsoNet® - OptiPure's patented scale inhibiting technology helps protect equipment against scale and corrosion for the rated capacity of the system.
- Reduces maintenance frequency and cost, and extends equipment life.
- Gradient-density sediment filtration protects against dirt, rust and other debris.
- High-capacity activated-carbon filtration makes water taste great and protects equipment against corrosive chlorine.
- New manifold design provides fewer possible leak points.
- Sturdy, powder-coated mounting bracket and multi-function valve simplify installation.
- Multi-function valve provides:
 - * Shutoff valve for quick and simple filter replacements
 - * System bypass valve for easy system maintenance
 - * Flush port to flush cartridges after installation
- Built-in pressure gauge allows visual monitoring of when filters need to be changed.
- Utilizes Qwik-Twist cartridges that make changing filters quick, easy and sanitary.



Application

ICE - Multiple cubers up to 2,000 lbs.

Installation Tips

- Feed-water connection to system should be COLD only.
- Do not exceed system specifications for temperature and pressure.
- Allow 3" clearance below system for filter cartridge removal and cartridge replacement.
- Connect filtered water line to ice connection only. Do not use for condenser water.
- Detailed installation, operation and maintenance manual included with each system.
- No activation procedure or flushing required for system to perform as specified.

OptiPure

Model: **QTI-4**
Part #: 170-52042

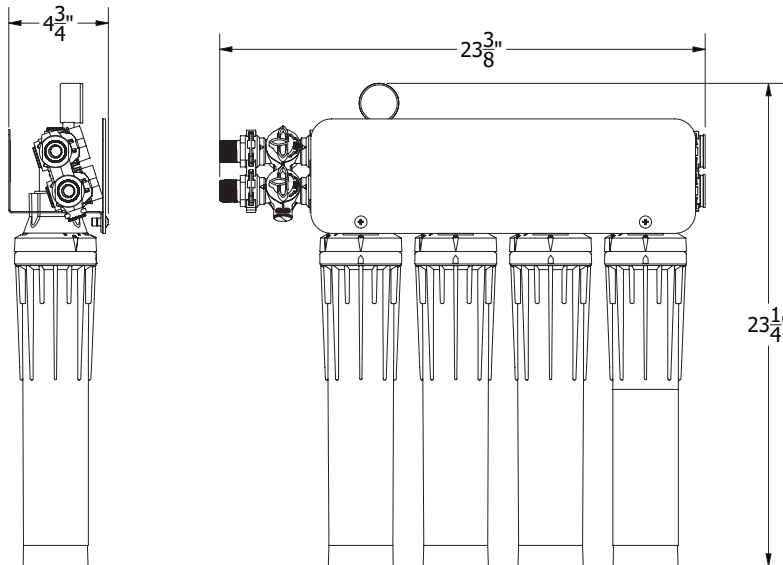

WARNING:
Cancer and Reproductive Harm -
www.P65Warnings.ca.gov

► Warranty

All system components and assembly except for filter cartridges, separation membranes, permeate pumps, electric motors, diaphragm pumps, and rotary vane pumps shall be warranted against defects in workmanship for a period of 60 months from the date of original shipment. For complete warranty information, contact OptiPure customer service or go to www.optipurewater.com.

Dealer/Distributor Info:

► Specifications

System	
Dimensions (Height x Width x Depth, Inches)	23 1/4" x 23 3/8" x 4 3/4"
Connection - Inlet & Outlet	3/4" MNPT
Operating Pressure Range	10 - 125 psi (0.7 - 8.6 bar)
Inlet Water Temperature Range	35° - 100°F (2° - 38°C)
Shipping Weight	16 lbs.
Performance	
Chlorine, Taste and Odor Reduction Capacity	90,000 gals. (340,687 L)
Service Flow Rate	9.0 gpm (34 lpm)
Sediment Reduction	0.5 microns (nominal)
Scale & Corrosion Inhibitor	280 grams

► Replacement Cartridge(s)

Model	Part Number	Qty
CTOS-Q	300-05835	4

► Options

Model	Description	Part Number
Fitting Kit	1/2" PTC Fitting Kit	575-92272

It is recommended that pre/post-filters and mineral addition cartridges are changed every 6 months, when capacity is reached or when feedwater pressure or flow becomes inadequate.

Membrane life varies depending on feedwater conditions and pre-filter maintenance. It is 12-18 months under typical conditions, but it can be as long as 3-5 years.

This product is for commercial use only and must be installed and maintained according to manufacturer's guidelines.

Do not use on water that is microbiologically unsafe or of unknown quality without adequate disinfection before or after the system.

OptiPure, A Division of Aquion, Inc.

101 S. Gary Ave., Suite A
Roselle, IL 60172

p: 972.881.9797 e: info@optipure.net
www.optipurewater.com