



Snapshot

The CTOS-CK10 is a compatible replacement cartridge for the Cuno® 8000 Series filter replacement cartridges. It is a 10" quick-change cartridge that reduces sediment down to 0.5-microns and reduces chlorine, taste & odor at a flow rate of 1.5 gpm for 15,000-gallons. The cartridge includes IsoNet®, OptiPure's patented scale-inhibiting technology, which delivers consistent protection against the precipitation and accumulation of scale and provides a protective barrier to help guard against corrosion.

Cartridge Benefits

- IsoNet® - OptiPure's patented scale inhibiting technology delivers up to 5 times more protection against scale and corrosion than most 8000 Series cartridges.
- Improves the quality and consistency of cold and hot beverages.
- Gradient-density sediment filtration protects against dirt, rust and other debris down to 0.5-microns.
- High-capacity activated-carbon filtration makes water taste great and protects equipment against corrosive chlorine.
- Provides more capacity than most 8000 Series cartridges.
- Replaces 3M® Cuno® 8000 Series sanitary quick change cartridges that include scale inhibition.

Model: **CTOS-CK10**
Part #: 300-08015

REPLACEMENT CARTRIDGE

ITEM #: _____ QTY: _____

JOB NAME/NUMBER _____



Application

Replacement Cartridge for 3M® Cuno®
CFS8112S, CFS8112ELS, CFS8112XS, CFS8720S
and CFS8720ELS cartridges

Ice Machines, Coffee Brewers and Steam
Equipment

Installation Tips

- Insure cartridge is designed to replace the existing cartridge.
- Do not exceed cartridge specifications for temperature and pressure.
- Allow 3" clearance below system for filter cartridge removal and replacement.
- No activation procedure or flushing is required for cartridge to perform as specified.
- Feed-water connection to system should be COLD only.



Model: **CTOS-CK10**
Part #: 300-08015

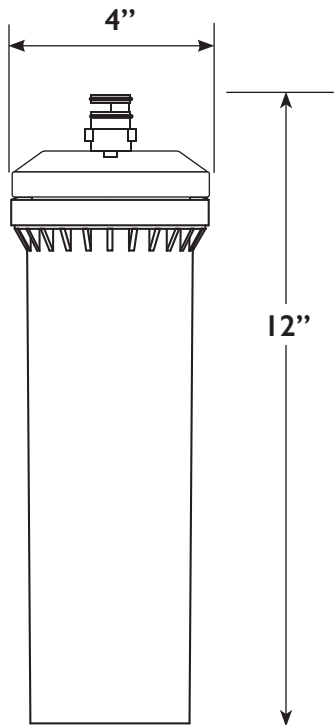

WARNING:
Cancer and Reproductive Harm -
www.P65Warnings.ca.gov

► Specifications

Cartridge	
Dimensions (Height x Width x Depth, Inches)	12"h x 4"w x 4"d
Operating Pressure Range	10 - 125 psi (0.7 - 8.6 bar)
Inlet Water Temperature Range	35° - 100° F (2° - 38° C)
Shipping Weight	5 lbs.
Performance	
Chlorine, Taste and Odor Reduction Capacity	15,000 gals. (53,781 L)
Service Flow Rate	1.5 gpm (5.7 lpm)
Sediment Reduction	0.5 microns (nominal)
Scale & Corrosion Inhibitor	IsoNet® (70 grams)

► Replaces CUNO Cartridges

Model	Part Number
CFS8112 S	5581708
CFS8112 ELS	5581727
CFS8112 XS	5601103
CFS8720 S	5631904
CFS8720 ELS	5632001

It is recommended that pre/post-filters and mineral addition cartridges are changed every 6 months, when capacity is reached or when feedwater pressure or flow becomes inadequate.

Membrane life varies depending on feedwater conditions and pre-filter maintenance. It is 12-18 months under typical conditions, but it can be as long as 3-5 years.

This product is for commercial use only and must be installed and maintained according to manufacturer's guidelines.

Do not use on water that is microbiologically unsafe or of unknown quality without adequate disinfection before or after the system.

► Warranty

Replacement filter cartridges are warranted for defects in material and workmanship only. Service life of replacement filter cartridges varies significantly with local water conditions and volume and thus cannot be warranted. Furthermore, separation membranes are equally susceptible to feed water conditions (e.g. presence of iron, alum and silica) and shall be warranted only for defects in construction. Membrane failure due to fouling, hydrolysis, oxidation or other damage caused by the local water conditions is not covered under warranty. For complete warranty information, contact OptiPure customer service or go to www.optipurewater.com.

Dealer/Distributor Info:

OptiPure, A Division of Aquion, Inc.
101 S. Gary Ave., Suite A
Roselle, IL 60172
p: 972.881.9797 e: info@optipure.net
www.optipurewater.com