



Installation, Operation & Maintenance Manual

For: Manifold Series QTCR

Models:		
QTCR-2	QTCR-3	QTCR-4

101 S. Gary Ave Roselle, IL 60172
www.optipurewater.com
(972)881-9797

DO NOT DISCARD - GIVE THIS MANUAL TO THE OWNER AFTER INSTALLATION

- Installation must conform to all local plumbing codes and regulations.
- Do NOT use with water that is microbiologically unsafe or of unknown quality without adequate disinfection before or after the system.
- Connect system to cold water supply only! Water temperature must not exceed 100°F/38°C.
- Do NOT solder plumbing connections attached to the assembly. High temperature will damage these components.
- Do NOT over-tighten fitting connections. Always back-up valves and fittings with a wrench to avoid turning the valve.
- Allow a minimum of 3" under the housing to allow for sump removal and filter replacement.
- Do NOT mount the system near a heat source or above the electrical wiring or any device or area that would be adversely affected by water.
- Do NOT mount the system behind equipment. The unit must be easily accessible for filter replacement.
- Failure to change cartridges per recommended intervals with OptiPure replacement cartridges may lead to system failure and property damage.

Introduction:

Your new OptiPure QT-Series FoodService Filtration System will cleanse and condition the tap water providing optimum water characteristics for their specified applications. The result is reduced equipment maintenance requirements, longer equipment life and improved quality & consistency of your products. The OptiPure System is built with the finest, most advanced materials and each system is quality inspected and pressure tested prior to shipment. Proper system installation and routine filter changes will ensure years of trouble-free operation and performance.

Please refer to this manual when performing routine filter changes. The instructions make periodic maintenance quick and easy, and ensure you will receive maximum benefit from your system.

OptiPure Limited Warranty:

All system components and assembly except for replacement filter cartridges, separation membranes, permeate pumps, electric motors, diaphragm pumps, and rotary vane pumps shall be warranted against defects in workmanship for a period of 60 months from the date of original shipment.

Replacement filter cartridges are warranted for defects in material and workmanship only. Membrane failure due to fouling, hydrolysis, oxidation or other damage caused by the local water conditions is not covered under warranty.

Permeate pumps, electric motors, diaphragm pumps, and rotary vane pumps shall be warranted against materials and workmanship for a period of 12 months from the date of purchase and are limited to the terms of warranty extended by the original equipment manufacturer.

Products should only be installed and operated in accordance with the recommended procedures and guidelines from OptiPure. Products must be maintained and serviced with OptiPure approved replacement parts and filters. Failure to replace filter cartridges or filter elements at recommended interval or specified capacity will void warranty.

Contact OptiPure customer service or go to www.optipurewater.com for a detailed copy of the warranty statement.

Obtaining Warranty Service:

To obtain warranty service the customer should:

- 1) Contact the authorized OptiPure dealer who supplied the product.
- 2) Call OptiPure's customer service department for replacement parts and support.



Filtertrak® is an online application that enables low maintenance service and filter monitoring of water treatment systems, ensuring customers get the full performance of their system.

FilterTrak manages timely, proper filter replacement which:

- Reduces maintenance
- Improves operating efficiency
- Assures the quality of ice, beverages, and steam generating systems

For more information about FilterTrak, please contact one of our foodservice master distributors or go to: www.optipurewater.com

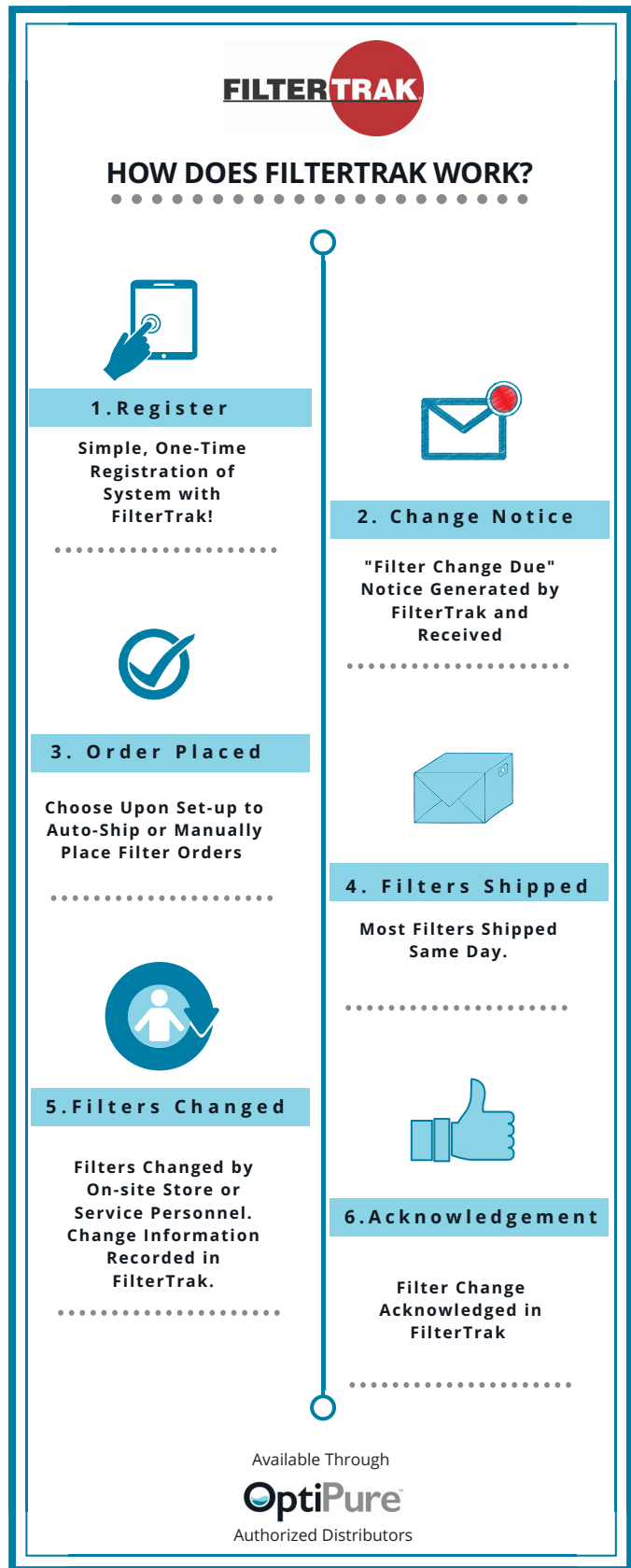

System/ Operating Specification & Connections:

Maximum Pressure: 125 psi/8.6 bar

Operating Temperature: 35° - 100°F (2° - 32°C)

Inlet/Outlet Connections:

1/2" NPT Male Fittings Standard on QTCR- 2, and QTCR-3 Systems

3/4" NPT Male Fittings Standard on QTCR-4

1/2" Push-In-Tube Connection are optional.

Certification Information:

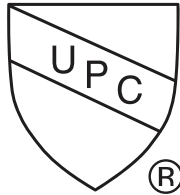

QTCR-2, QTCR-3 and QTCR-4 models are certified by IAPMO R&T to NSF/ANSI Standard 42 for the reduction of Chloramine, Chlorine, Taste, Odor and Particulate Class III.

Capacity:

Change filters at gallon rating or at least every 6 months, or when pressure gauge needle enters the red zone on the outlet gauge while water is flowing through the filter system under normal operating conditions.

Model Name	Flowrate		Capacity		Scale Inhibitor Media	Reduction of
	gpm	lpm	gallons	Liters		
QTCR-2	3.4	12.9	20,000	75,700	No	Chloramine, Chlorine, Taste , Odor & Particulate Class III
QTCR-3	5.1	19.3	30,000	113,550	No	Chloramine, Chlorine, Taste , Odor & Particulate Class III
QTCR-4	6.8	25.7	40,000	151,400	No	Chloramine, Chlorine, Taste , Odor & Particulate Class III

All contaminant reduction claims are valid only if actual flow rate do not exceed the rated flow.

Dimensional Drawing:

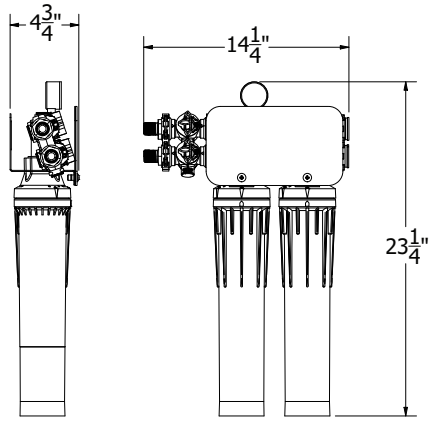

Model: QTCR-2

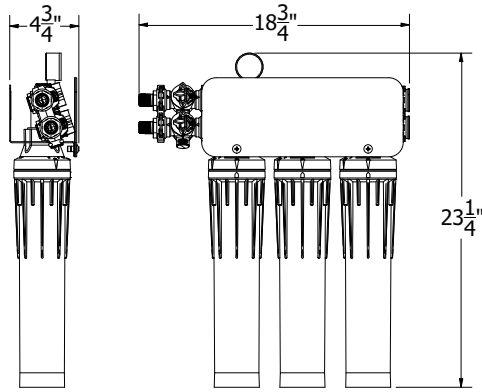

Model: QTCR-3

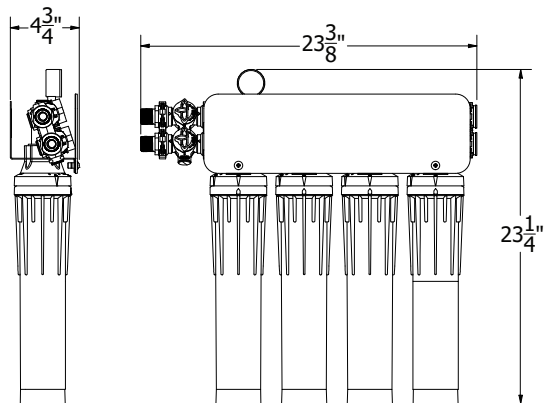

Model: QTCR-4

Installation Precautions:

- Do NOT install system on line pressure above 100 psi.
- Do NOT install the system backwards with the feed water line connected to the outlet.
- Do NOT use liquid pipe compounds for fitting connections. USE two to three wraps of PTFE thread sealant tape.
- Do NOT allow system to freeze. Turn off water supply to housing and drain housing if temperature falls below 33°F.
- Do NOT install system in direct sunlight or where system is exposed to harsh chemicals or may be subjected to being struck by moving equipment, carts, mops or any other item that may cause damage.
- IF water hammer is evident, install water hammer arrestors before OptiPure unit.

Installation Procedure :

1. Turn off all equipment to be fed by the OptiPure System.
2. Locate water supply cut-off valve and turn off.
3. We recommend that you install a full-flow ball valve of the same size or larger than the connection fittings on the OptiPure System. Installing a ball valve on the line supplying the OptiPure System allows the system to be serviced without shutting off the main water supply. (It will not be necessary to use this valve when replacing filters.)
4. Mount the OptiPure System on a wall stud or suitable mounting material spanning wall studs.

NOTE: QTCR-4 Systems full of water can weigh up to 35 lbs. Use suitable fasteners when mounting to wall.

5. Run a 1/2" Piping/ Tube or 3/4" Piping / Tubing or larger feed line from the full-flow ball valve to the top INLET Connection on the left side of the OptiPure system. For NPT connection: Use 2-3 wraps of PTFE Thread sealant tape and hold the inlet male fitting on the system with a wrench when connecting the feed water line.

NOTE: Ensure all piping / tubing being attached to OptiPure System is properly supported, to ensure proper alignment and that piping / tubing can allow movement associated with the expansion and contraction of the piping system. Use hangers and anchors of proper strength to maintain the proportional share weight of the piping / tubing and contents. Improper piping / tubing support can cause undesired stress and fatigue on plastic fittings of OptiPure System causing system failure.

NOTE: Do not overtighten connection fittings.

Mounting Dimensions

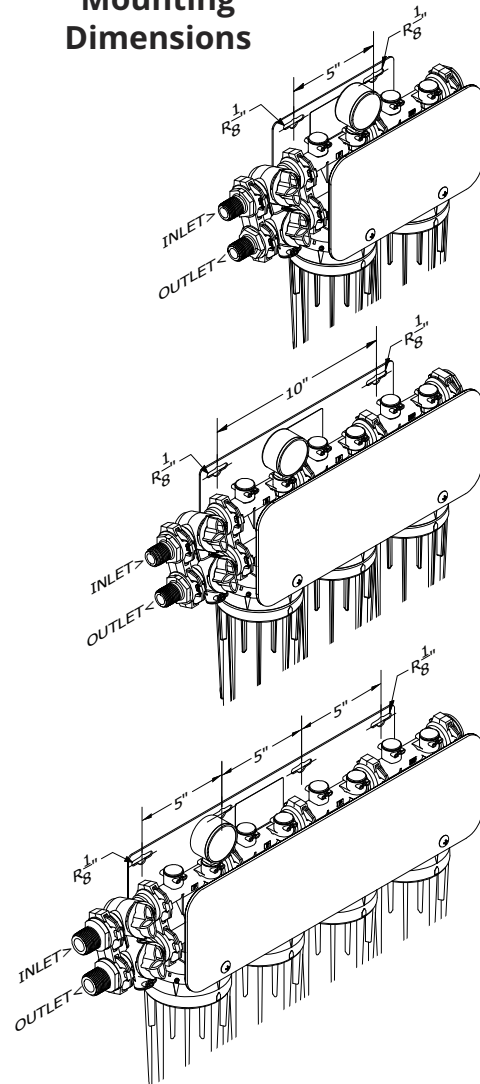

Installation Procedure (continued):

6. Select the appropriate size tubing for the equipment being fed and connect it to the OUTLET of the OptiPure System.

Unless Flush Valve Assembly or Flushing Line is installed prior to making connection to the equipment, DO NOT connect the tubing from OUTLET of OptiPure System to the equipment at this time, this tubing from the OUTLET can be used to flush the system.

7. With OptiPure Multi-Function Valve set in the off position (See Figure 2 on page 10), slowly open the full-flow ball valve at the water source.

Check for leaks from plumbing leading into the OptiPure System.

8. Flushing of system before use.

Three possible flush port connections:

(NOTE: a. and b. allow for convenient flushing after filter replacement.)

- a. A Flush Valve Assembly included in the parts pack can be attached to the Multi-Function Valve port opening. See page 15 for more information. When using this option, connect the system outlet tubing to the equipment before flushing.
- b. A tee (not supplied) can be added on the outlet line from the system. Install a manual shut-off valve (not supplied) on the branch of the tee. When using this option, connect outlet tubing from the tee to the equipment before flushing.
- c. If no flush valve is installed, use the outlet tubing that is not yet connected to the equipment for flushing.

Flushing steps:

1. Hold tubing from the chosen flush connection in a bucket or over a sink or drain.
 2. Slowly turn the Multi-Function Valve top handle into the Operating Position. (See Figure 1 on page 10.) Turn Flush Valve Options a. / b. to open positions.
 3. Allow water to flush through the OptiPure System for 10 minutes.
 4. Turn Multi-Function Valve to the Off Position. (See Figure 2 on page 10.)
 5. If flush connection a. or b. is used, be sure to turn the shut-off valve to the Off position. If flush connection c. was chosen, connect the outlet tubing to the equipment at this time. Ensure that the tubing is clean before connecting to the equipment.
9. With tubing connected to equipment. Turn Multi-Function Valve to the Operating Position (See Figure 1 on page 10) and check for leaks.
 10. If no plumbing leaks, turn on equipment and check for normal operation of equipment.
 11. Register your System with FilterTrak.

Multi-Function Valve

The OptiPure Manifold System includes a Multi-Function Valve that allows the System to have the water turned off, or be put into bypass. The white handles on the valve provide a clear indication of the water flow path in each position. The three points on the tee shape of the handle indicate a path the flow can take.

Operating Position

This is the position of the handles during normal operation. Looking at the handle pointers, you can see that feed water flows from the INLET port into the filter system and treated water flows out of the system to the OUTLET port. The bypass path from inlet to outlet is blocked.

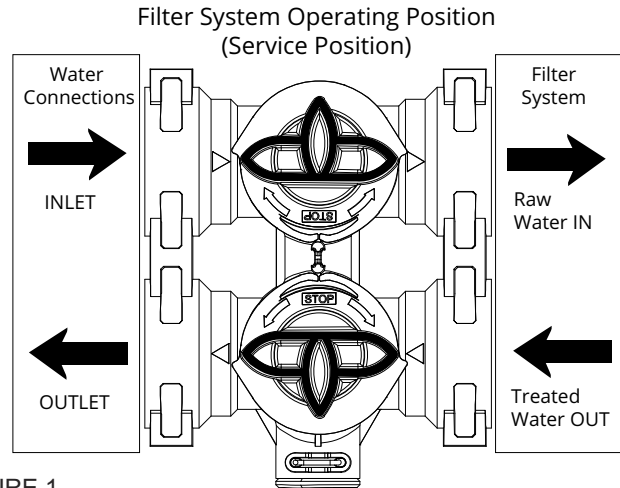

FIGURE 1

Off Position

In this position, the inlet water is stopped before entering the OptiPure System.

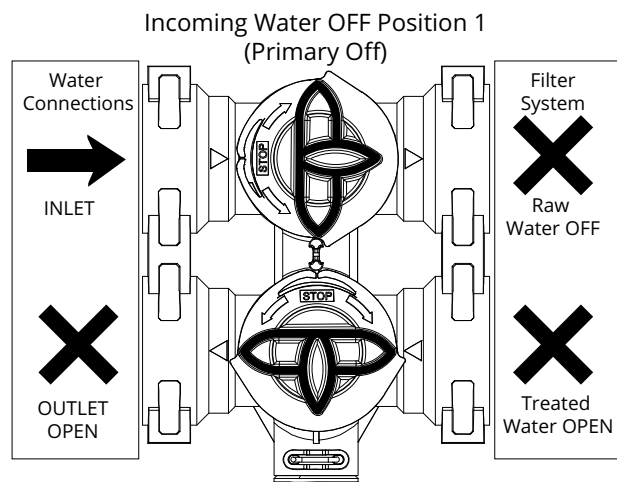

FIGURE 2

Bypass Position

In this position, the INLET water is diverted to the OUTLET port and all flow to and from the filters is blocked.

Equipment does not have treated water at this time, so this should only be used when issues with filtration are occurring.

Alternate Bypass Position is used when Outlet connection is switched to right side of manifold. Note: Non treated water is flowing thru manifold at this time. See page 11 for Alternate Outlet Location.

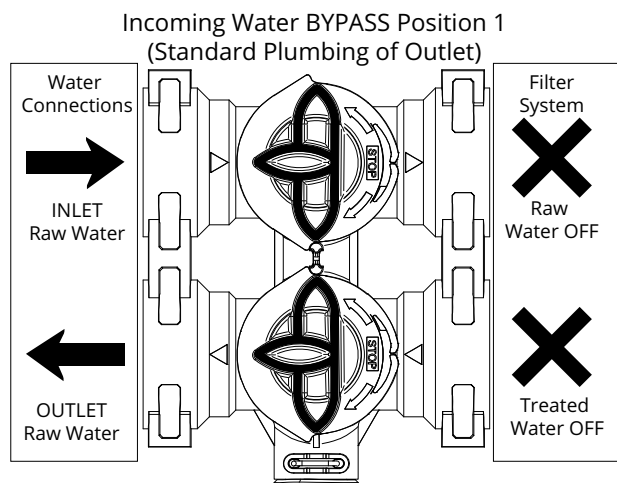
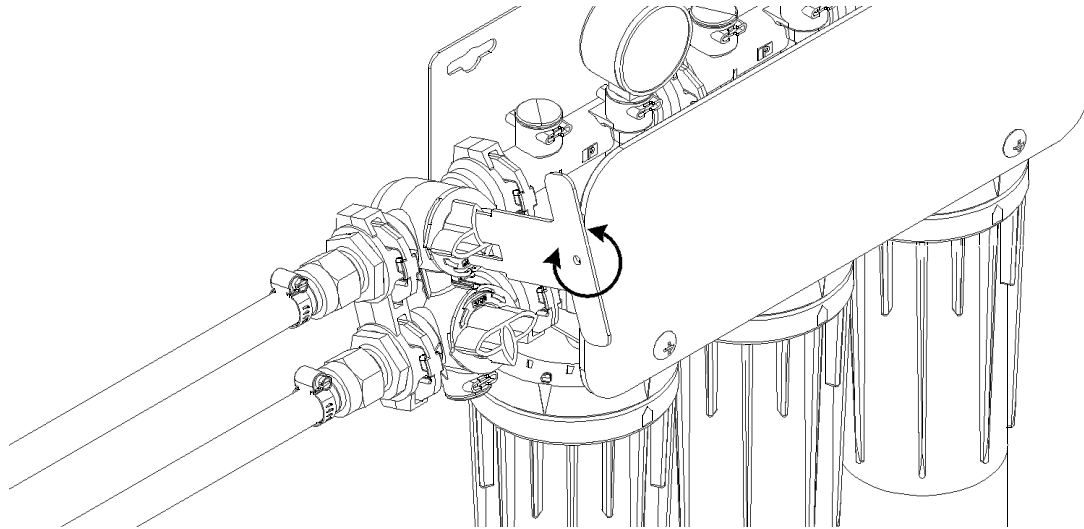

FIGURE 3

Multi-Function Valve Wrench

The OptiPure Manifold Systems include a wrench to help turn the Multi-Function Valve positions. Insert wrench as shown to help rotate handles 90 degrees in each direction from Service Position.



Alternate Outlet Locations

The OptiPure Manifold System has the ability to be flexible with treated water outlet locations. The outlet fitting can be switched to the other end of the Manifold System if Inlet and Outlet needs to be on opposite sides of the system.

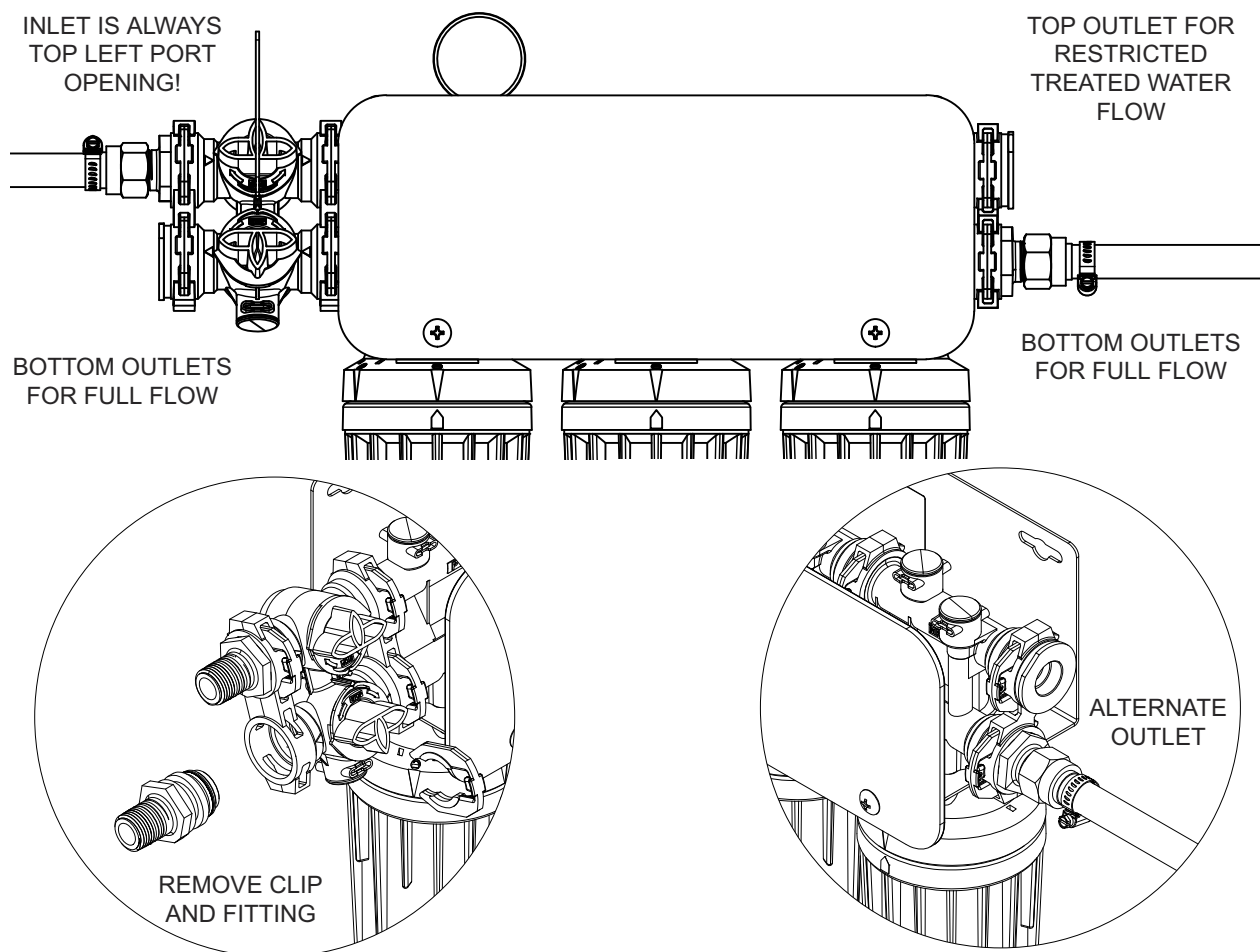

Replacement Filter Cartridges:

OptiPure Filter Systems are designed, tested, and certified with OptiPure filter cartridges with proven performance, size and operating capacities. Use of replacement cartridges other than those specified will void warranties, certifications and may compromise equipment protection, water quality and cartridge life.

Replacement Cartridges:

System	Cartridge	Part Number	Qty.
QTCR-2	CTO-QCR2	300-05833	2
QTCR-3	CTO-QCR2	300-05833	3
QTCR-4	CTO-QCR2	300-05833	4

Operation:

With adequate pressure, normal operation of the OptiPure System is completely automatic. Dependable operation involves only monitoring of outlet pressure, periodic filter changes and service documentation.

Filter Change Frequency:

Several situations will mandate filter changes. Complete filter sets should be changed when any of the following apply:

- Six (6) Months have passed since unit installation or previous filter change.
- Reduced water flow.

If filter change frequency is less than 6 months due to pressure drop, it may be necessary to add additional prefiltration or evaluate system sizing recommendations.

Filter Cartridge Replacement Procedure:

IMPORTANT: Determine whether all equipment connected to the OptiPure System must be turned off prior to shutting off water supply from filters.

1. On Multi-Function Valve Turn Upper handle to the OFF Position. (See figure 2 on page 10)
2. Relieve pressure downline by opening flush valve or briefly actuating equipment.
3. Turn cartridge to the left 1/4 turn until the cartridge stops.
4. Pull down on the cartridge until the cartridge clears the system connection. Discard old cartridge. **NOTE:** Some water will drip from Optipure System during cartridge removal.
5. Line up the upward-arrow on the new cartridge with the arrow on the side of the cartridge connection on the Optipure System. **NOTE:** Some cartridges do not have arrows. Reference the Key Feature in figure when connecting to system.
6. Push cartridge up into head until the base of the cartridge is next to the base of the filter system. Turn the cartridge to the right about a 1/4 turn or until the cartridge stops.

REPEAT Steps 3 thru 6 on additional filters.

7. On Multi-Function Valve Turn Upper Handle to the Operation Position. (See figure 1 on page 10)
8. Open down-stream flush valve to flush new cartridge for 10 minutes.

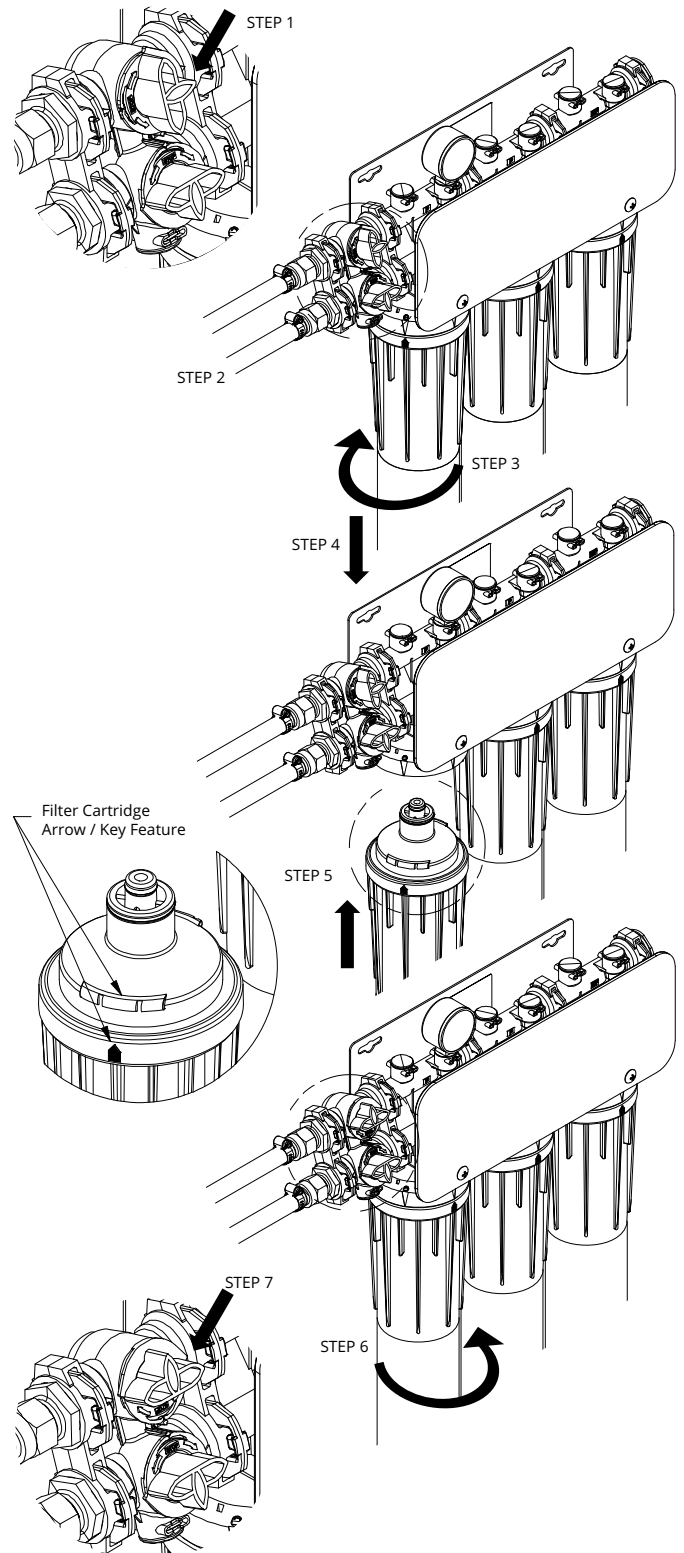



Pressure Gauge Monitoring:

Periodically monitor the pressure gauge on the OptiPure System. If the needle on the gauge ever enters the red zone (while the connected equipment is in operation and water is flowing through the system to the equipment) it may be an indication that the filters have become clogged.

Maintenance:

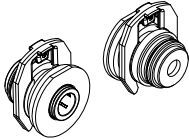
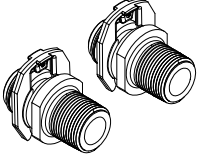
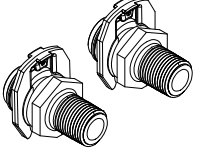
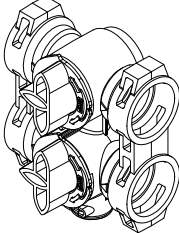
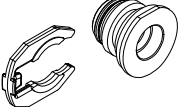
The only routine maintenance your OptiPure System should ever require is periodic filter cartridge changes. Filter changes are necessary for optimum performance of your foodservice equipment. If the system sizing recommendations have been followed the OptiPure System is designed to provide a six (6) month filter replacement interval on most tap water.

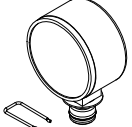
OPTIONAL KITS & REPLACEMENT PARTS		
	KIT #: 170-52912	Optional Kit Flush Valve Assembly (1) Flush Valve Assembly (8ft) - 3/8" (TUBE NOT SHOWN)
	KIT #: 575-92272	Optional Fitting Kit 1/2" Tube Connection (2) - Connectors, O-rings, Clips
	KIT #: 575-92273	Optional Fitting Kit 3/4 NPT MALE Connection (2) - Connectors, O-rings, Clips
	KIT #: 575-92274	Optional Fitting Kit 1/2 NPT MALE Connection (2) - Connectors, O-rings, Clips
	Part: 575-92274	Replacement Assembly / Part Bypass / Multi-Functional Valve
	Parts: 575-92264 575-92225	Replacement Assembly / Part (1) Plug Assembly with O-ring (1) Manifold, Head Clip
	Parts: 575-92265 575-92230	Replacement Assembly / Part (1) Port Plug Assembly with O-ring (1) Manifold, Port Clip
	Parts: 575-92266 575-92230	Replacement Assembly / Part (1) PSI Gauge Assembly with O-ring (1) Manifold, Port Clip

Additional Replacement Parts

(Not Shown):

Part#	Description
19782	Multi-Function Valve Wrench
575-92233	O-Ring 0-118 (Body & Fittings)
575-92234	O-Ring 0-021 (Body)
575-92235	O-Ring 0-110 (Port)
575-92239	O-Ring 0-120 (Handle Lower)
575-92240	O-Ring 0-122 (Handle Upper)
575-92249	Cover 2 UP
575-92250	Cover 3 UP
575-92251	Cover 4 Up
575-92232	Cover Screw 1/4-.375 Black

Flush Kit Optional attachment to Multi-Function Valve

To install Flush Valve Assembly:

1. Turn Multi-function Valve to Off Position and relieve pressure to OptiPure System.
2. To remove White Port Plug on Multi-Function Valve remove Port Clip using small flat head screwdriver. Pull Port Plug out of Multi-Function Valve.
3. Insert Flush Valve Assembly into Multi-Function Valve Port. Replace Port Clip.
4. Install 3/8" Tubing (NOT INCLUDED) into ball valve and direct other end into bucket or sink. Ensure ball valve is in off position.
5. Turn Multi-Function Valve to the Operating Position and check for leaks.
6. Open ball valve on Flush Valve Assembly to verify water flushing. Turn ball valve off when flushing is complete.

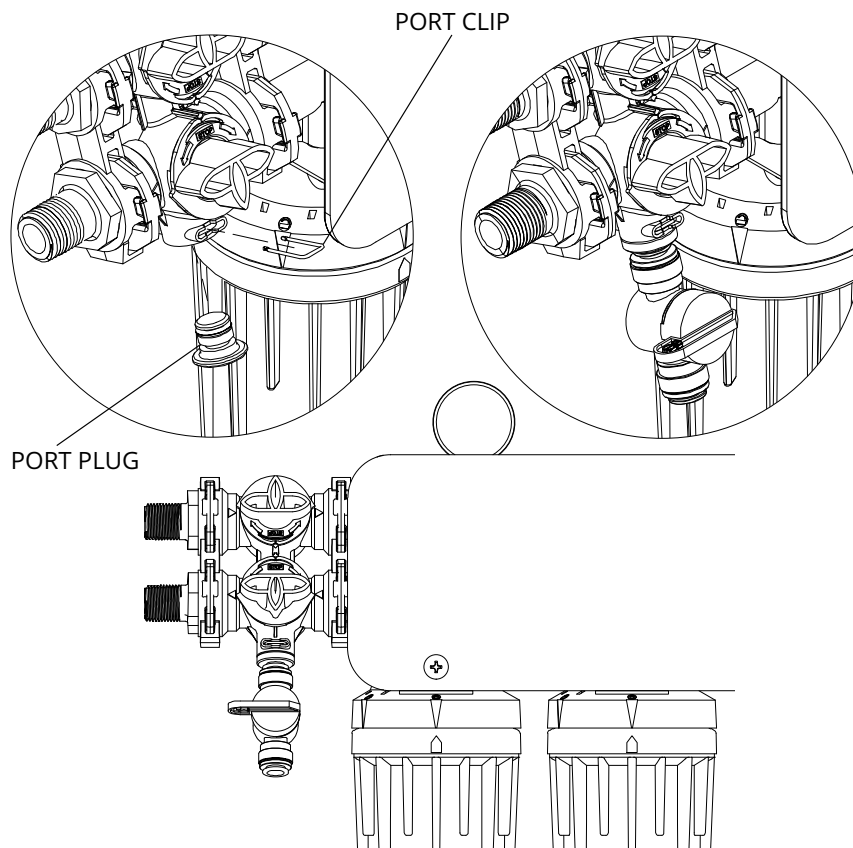

Manufactured by :

OptiPure, A Division of Aquion, Inc
101 S. Gary Ave., Suite A
Roselle, IL 60172
p: 972.881.9797 e: info@optipure.net
www.optipurewater.com